

CATALOG #10

GARY GOERS

CLASSIC CAR INTERIOR RESTORATION

1950s
\$5.00 (US)

NEW & REPRODUCTION
PARTS
FOR
CHRYSLER CORP. AUTOMOBILES
1955 AND LATER

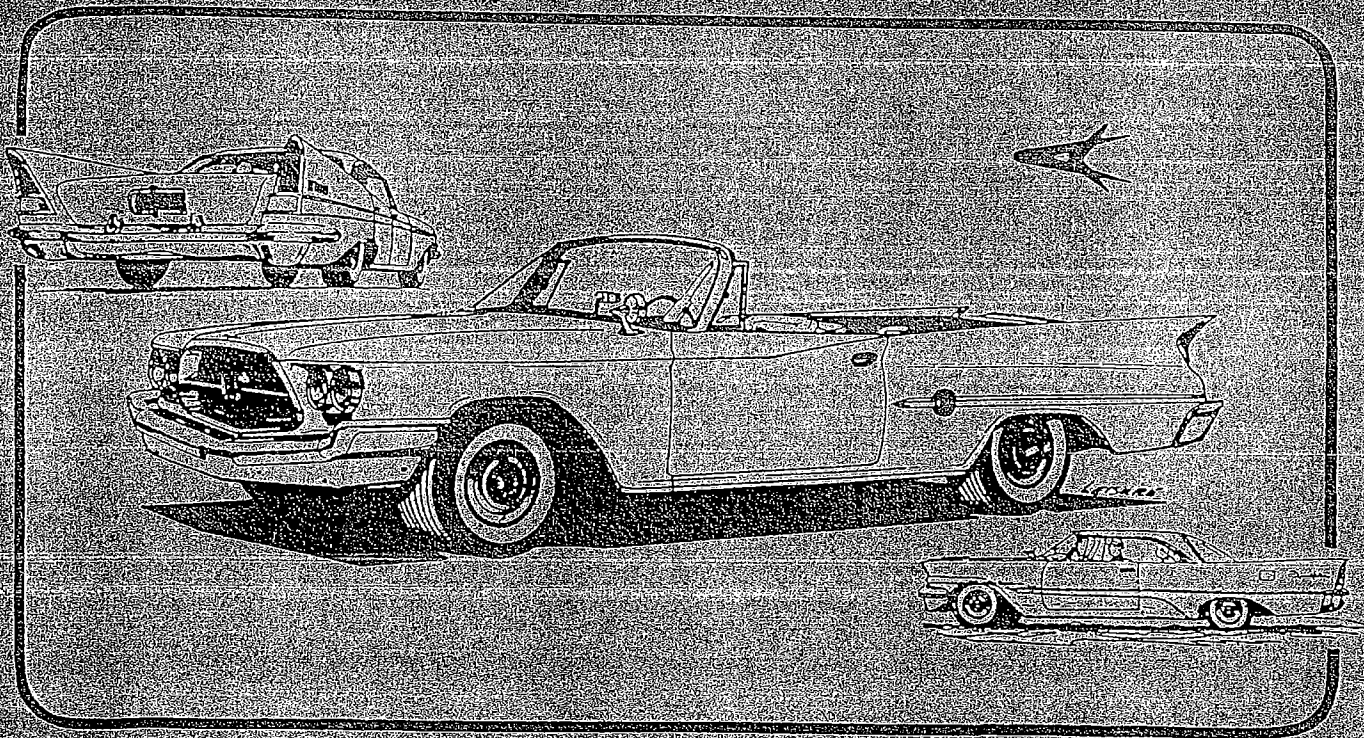

(406)752-6249 Fax

37 Arndahl Lane Kalispell, MT 59901

World Wide Web (<http://www.garygoers.com>)

Email (gary@garygoers.com)

PLYMOUTH ♦ DODGE ♦ DE SOTO ♦ CHRYSLER ♦ IMPERIAL

FIRST, A FEW WORDS OF INTRODUCTION

I have been restoring Chrysler products since 1966 and producing parts for them for over 35 years. That makes me real old or real dumb or both! I started making parts since there were next to none available and the business grew from there. The variety of parts grew over the years and I try to keep everything I ever had in current supply. This has not always been possible especially lately. Catalog #9 was around for many years and getting rather scattered. This catalog #10 is a bit better with almost everything in its proper category. Sorry for any typos or other goofs. There have been the inevitable price increases and some reality checks on some items such as carpets. Color choices from standard suppliers have dwindled to very few and, with few exceptions, I'll have to resort to offering only black in loop or cut pile. Continue ordering as usual and I'll let you know if there is a problem and the best way to solve it. Everything I have or reproduce is in this catalog except for the 300 letter car interiors which are in a separate sheet upon request. Thanks to you all for years of support and thanks to Brad Leisure for his many small parts drawings (poor ones are mine)

INDEX

Gary

INTERIOR

Gas and brake pedals	1
Dash parts, steering column seal, seat parts	2-3
Floor carpets, windlace, upholstery	4
Chrome screws, dash parts	5
Rubber floor mats, aluminum inserts	6
Top boots, top wells	7
Glove boxes, firewall pads	8

DOORS

Snubbers, bumpers	9
Molded weatherstrip ends	10-11-12
Door & quarter window weatherstrips	13
Glass run channels	14
Station wagon parts	15

TRUNK

Snubbers, gaskets, body plugs	16
Trunk weatherstrip	16-17
Trunk carpets & spare tire covers	17
Trunk panels	18
Jack sheets & hood pads	19

UNDERHOOD

Hood pad	19
Hood pad clips, hose clamps	20-21
Grommets	20, 21, 22, 23, 24
Heater drain seals	21
Wire loom straps	22

HOODSTOPS

Hoodstops	25
Relays, oil & temp senders	26
Dist. leads, solenoids switches	27
radiator support & cowl to hood seals	

SPLASH SHIELDS

Splash shields	28, 29, 30
----------------	------------

BODY

Front & rear bumper shields	30
Body plugs, rear bumper guard pads	31
License plate snubbers, gas door bumpers, body mounts, bumper bolts	32
Headlight parts, socket & pigtails	33
Moulding clips	34, 35, 36

CONVERTIBLE PARTS

Convertible only parts	36
CVT. top header seals, side rail upper windshield post seals	37

HARDTOP PARTS

Roof rail weatherstrip	38
Roof rail weatherstrip ends	
Windshield & backglass rubber	39, 40
Windshield tools and supplies	40
Decals	41, 42, 43

GASKETS

Mirror, antenna, misc.	44, 45
Tail light, parking light, license	46
Back up light and housing gaskets	47

SUSPENSION

Bushings, snubbers	47, 48
Spring interliners, strut bushings	49
grease seals, fuel filler tube grom.	

MISC.

Windshield & back glass seals	50
New Chrome	50, 51, 52
Seat frame & floor plastic	53
New Reproduction lenses	54
Washer Bags	55

INTERIOR

I must have your old pedals to reuse the steel ones. Please send them in with your order.

84. Gas pedal '57-'59 Chrys., Imp.



253. Gas pedal '57-'59 Windsor, '59 Dodge Exchange

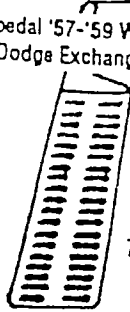

252. Brake pedal '57-'59 Windsor '59 Dodge Exchange

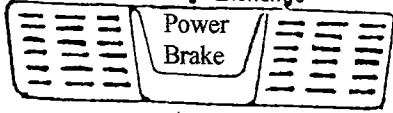

76. Brake pedal '57-'62 Dodge, Ply., '60-'62 Chrys, DeS. Also available without POWER BRAKE letters

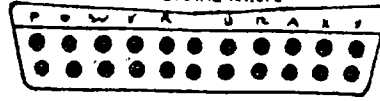

73. Gas pedal '57-'59 Ply., Dodge

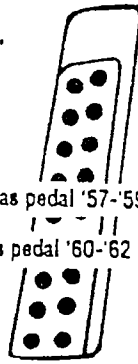

83. Gas pedal gray 9 1/2" '55, '56 Chrys., Imp. DeS., 7 1/2" '55, '56 Dodge, Ply.

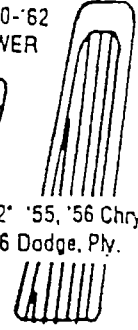

85. Brake pedal '57-'59 Chrys. POWER BRAKE

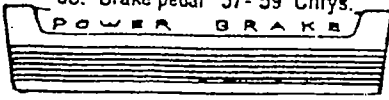

#257 Brake pedal '57-'59 Imp. [larger than Chrysler]

82. Brake Pedal Imp., Chrys., DeS., Ply., Some Dodge. '55-'56 Red or Grey, '57-'58 Black



available w/ POWER BRAKE lettering

284. Gas pedal '57-'59 Desoto

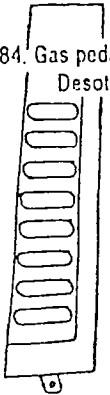

298. Brake pedal '57-'59 DeSoto

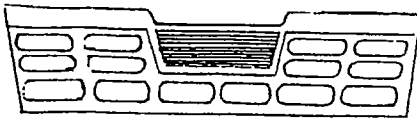

305. '60-'66 Valiant, Dart gas pedal

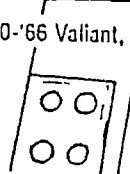

60. 62-'66 Dodge & Plym. gas pedal

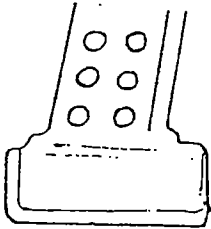

149. Brake pedal pad '60-'66 Dart, Val. auto

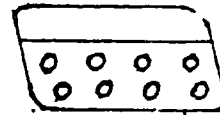
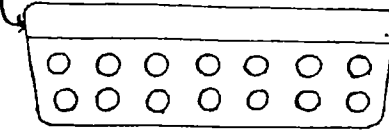

327. '61-'62 Chrysler brake & clutch pad. A- clutch slip on B- brake, need core

350A. A-body brake pedal pad, automatic trans.

B. Small pad for manual trans, brake & clutch.

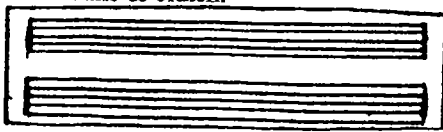

30. Vent pad '55-'58 [black, red, or gray]

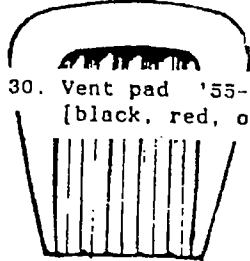

326. '68 Dodge gas pedal

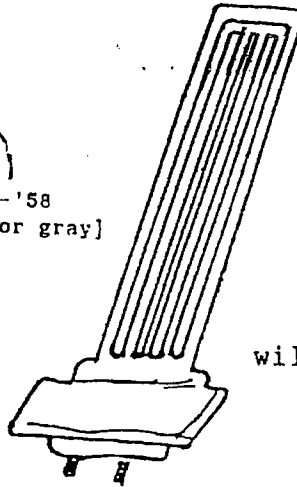

will also work on '55-'56

263. '57-'64 accel. pedal rod boot

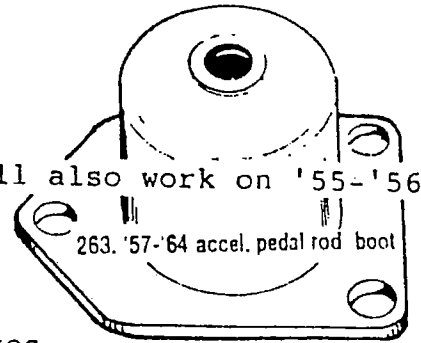

254. Manual brake and clutch pedal Pad '57-'65 also see 327

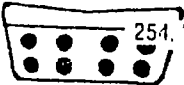

215. '57-'59 Imp. park pedal pad.

63. Parking brake pedal pad '60-'62 most cars, '63-'65 some cars.



#519 '57-'58 All makes. Temp. control lever sleeve. A-black ('57); B-white ('58)

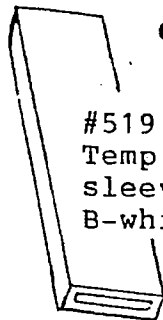

89. Front seat spring mount '57

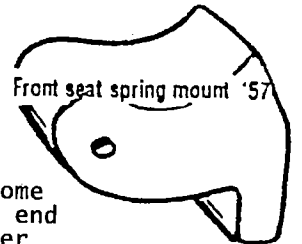

103. Windshield washer pad '57-'59 (black or white)

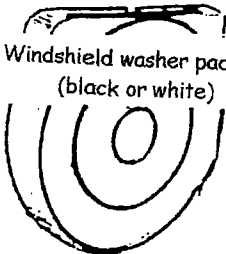

#485 '58-'64 some steering tube end insul. w/ power steering

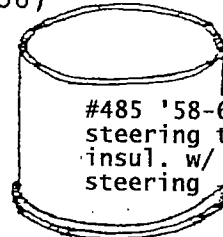

213. '60-'62 Chrys. glove box door stop arm grommet. Hard rubber



236. '57 glove box arm grommet



150. Spring for trans. Push button unit



138. Socket head set screw 10 x 3/8 uncs thread

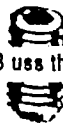

154. Pushnut for front bucket seat pins

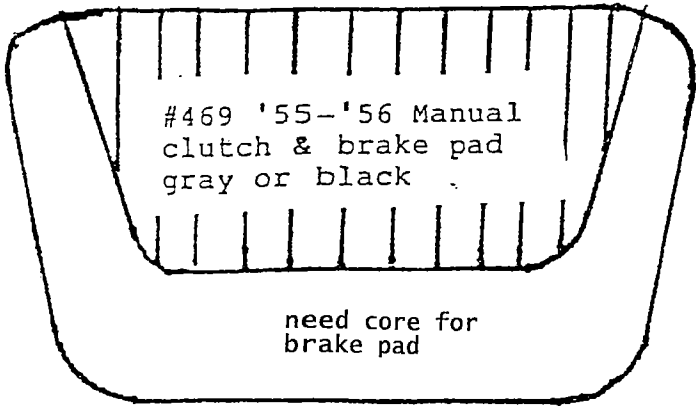

#469 '55-'56 Manual clutch & brake pad gray or black

need core for brake pad

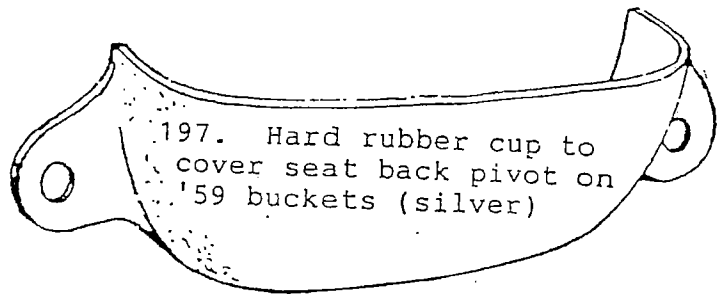

197. Hard rubber cup to cover seat back pivot on '59 buckets (silver)

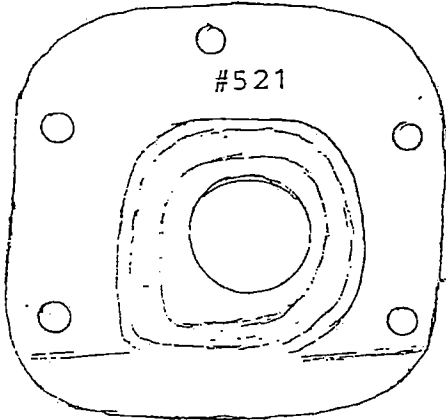

#521

521. '58-'59 Dodge, some Plymouth steering column / floor seal. Must have old core. see #333 pg. 3

#466 '60-'66 most bucket seats front seat back hinge cover. Black hard rubber

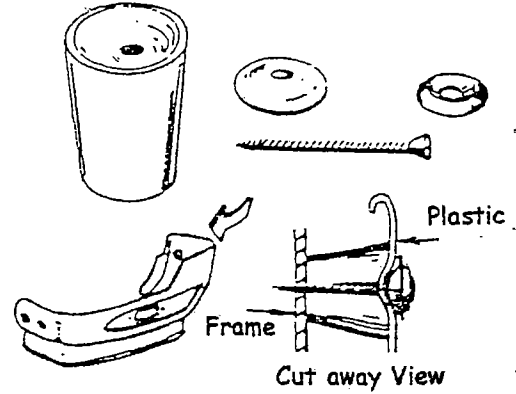
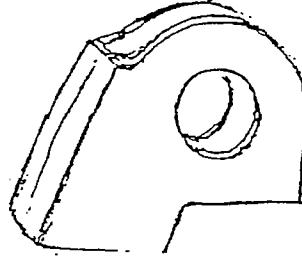

259. '57 front seat plastic mounting kit. custom designed to cure most mounting problems, even broken out mounting holes. 40 pc.

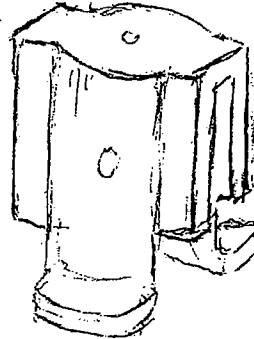

#24C '54 and earlier steering shaft insulator \$7.75

108. Mast jacket seal '55, '56 C, DeSoto

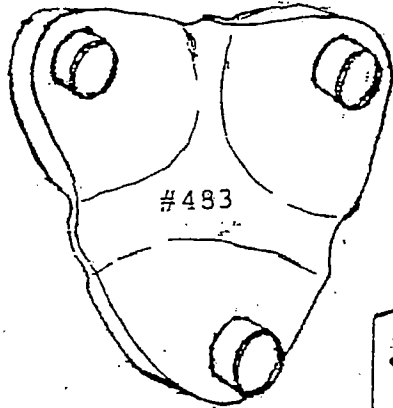
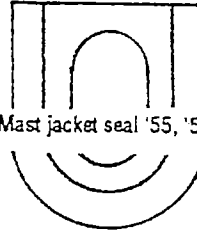

#483

'51-'52 Dodge steering box mounting pad, 2 req'd

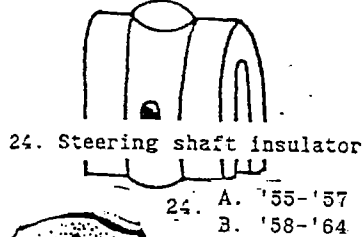

24. Steering shaft insulator
24. A. '55-'57
B. '58-'64

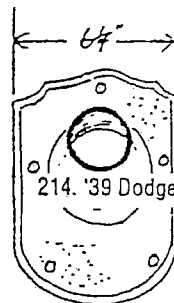

214. '39 Dodge

418 '60-'62 Exc A&B body Mast jacket seal
A. Long wheel base cars
B. Short wheel base cars

Exch, only see #449 top pg.3

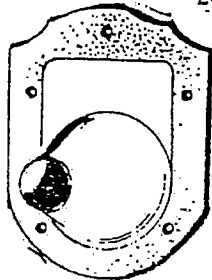

273. column seal '39 Chrys

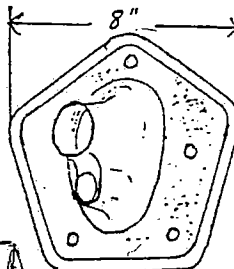

249. '40 Ply.

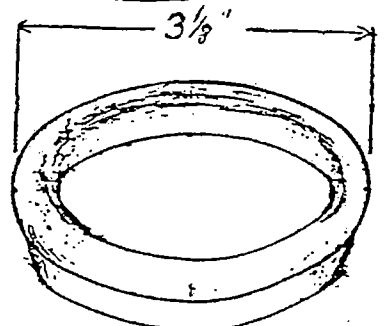
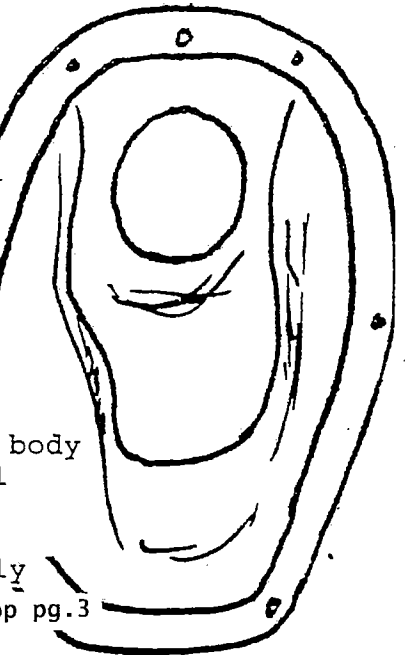

#458 '63-'66 A-body. Grommet on steering column base plate

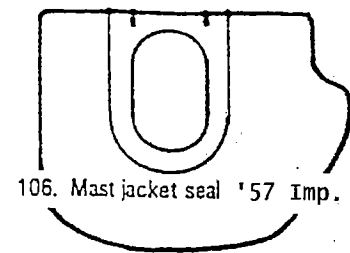

106. Mast jacket seal '57 Imp.



#561 '60-'62 visor tip \$5.00

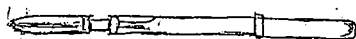

#606 '60-'62 visor tip white plastic see #561 \$8.00 each

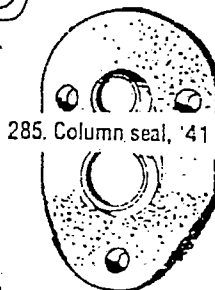

285. Column seal, '41 Ply.

328. Column seal for '56 Ply.
not pictured-similar to #334

449A. '60-'64 Full size,
long wheel base Chrysler,
secondary steering col.
Seal.

449B. Short wheel base full size cars
(see #418)

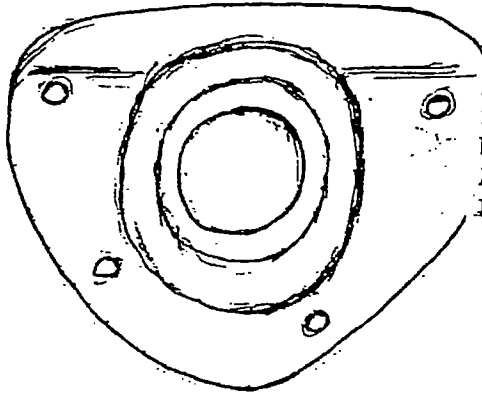

#450 Steering col. to
floor seal. Exchange.
Need your original metal
A. '57 Chrys., Des.
B. '58-'59 "some"

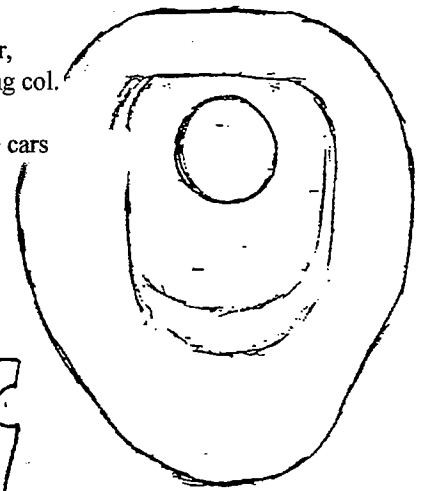

#333 '58-'59 Dodge,
Ply. steering column
seal. (also see #102AA)

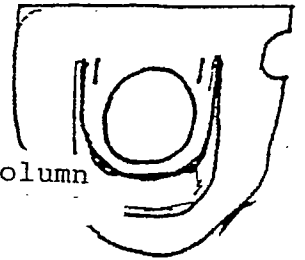
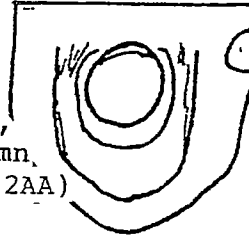

#334 '57 Dodge,
Ply. steering column
seal

472A. Manual steering
B. Power steering
'57 Dodge, some '57 Plymouth
steering column seal.
Need your old core.

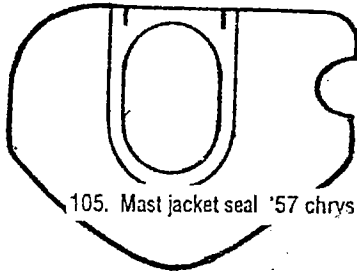
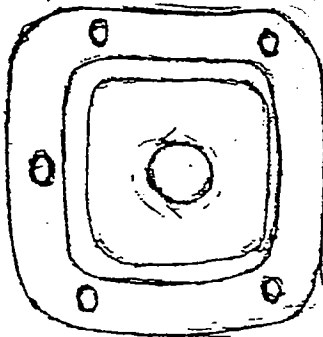

105. Mast jacket seal '57 chrys. DeS.

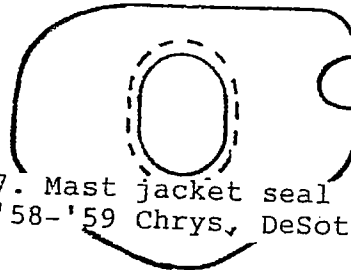

107. Mast jacket seal
'58-'59 Chrys, DeSoto

#431 Door sil
plate screw
8x $\frac{1}{2}$ truss head,
chrome



#428 STAINLESS STEEL STUDS
for convert. top boot snaps.
#8x1" Phillips head.



#430 Multi-purpose
black plastic fastener.
Replaces metal windlacing
clips.



426. Hog rings, 500 + pcs.

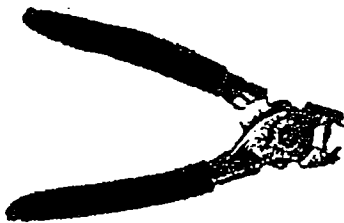

#427 HOG RING PLIERS
professional quality

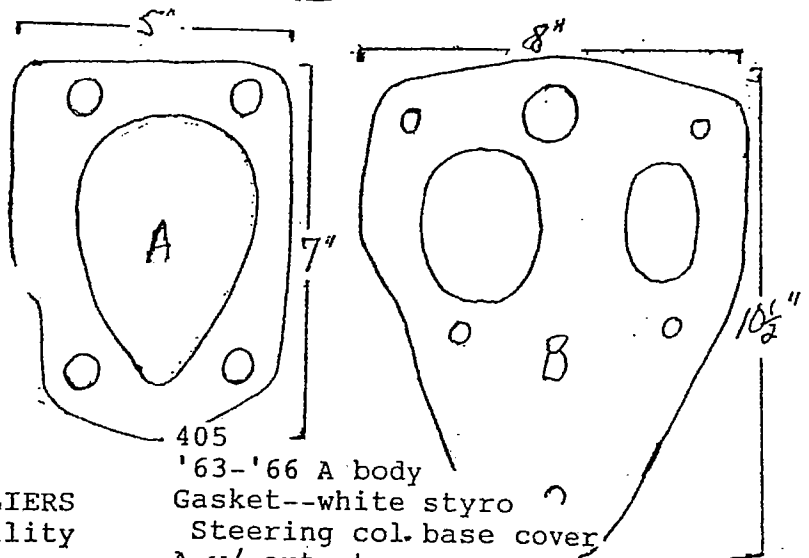

405
'63-'66 A body
Gasket--white styro
Steering col. base cover
A w/ auto trans
B w/ man trans

425. BURLAP Use over seat springs.

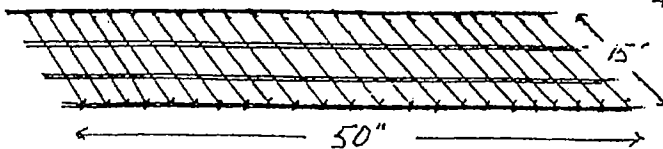

424 SEAT SPRING "LADDER" Helps distri-
bute weight evenly over springs. Replaces
old style tempered wire woven through
burlap. Can be cut for bucket seats.
Use over a burlap covering and hog ring
into place.

FLOOR CARPETS OTHER THAN '55 - '62 300'S

All prices below are for black material. Cost has increased dramatically in the last few years and color choices have decreased. Colors other than black will be 10% higher. Carpets are sewn and edged as original with reproduction heel pads for each year. Send a sample for the closest color match. The '55-'56 Chrysler; '55-'56 DeSoto and '60-'66 Imperial are priced \$170. The '57-'62 Chrysler; '57-'59 Dodge/Plymouth; '65-'68 C-body are priced \$140 for loop pile & \$150 for cut pile. '60-'62 are cut and sewn to replace the original molded carpets. Molded carpets are not available for most of these. Please state make, model, number of doors, and if it has power seats or manual seats.

CARPET PAD \$6.70/yard
High Quality easy-to-work-with synthetic jute
1/2" thick by 36" wide

Panel Boards

Attached to swivel seat track. Price for '59 all models is \$20.00 - can make the vinyl pieces other than black if you send 2 sq. Ft. of your vinyl.

Vinyl Skirt

Attached to '57 front seat cushion plastic (black) price is \$16.00 per set.

Console Inserts

Lined aluminum centers for '60 - '62 letter car consoles. Die cut exact reproductions. polished and anodized. Price is \$300.00 per set

Windlacing

The original cloth/ nylon type us no longer available. I carry a complete line of cloth - covered windlace which resembles the original. It is available in black, blue, navy, camel, fawn, brown, green, forest, silver, red, rust, maroon, and turquoise. with this comprehensive Color Range, I can match almost any color. Price is \$2.20 per foot. Other colors can be made with fine - knit vinyl, customed died to match your sample.

Price is \$3.65 per foot. Snap-on combo type for earlier A&B-bodies are also available in limited colors at \$20.00 per yard.

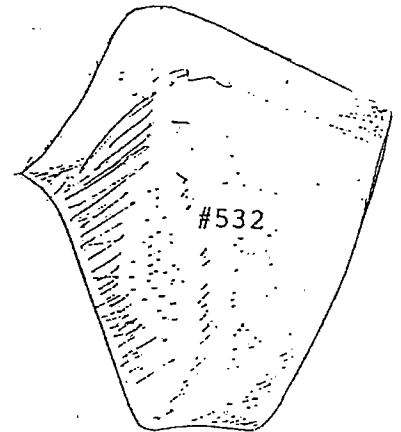

#532 '60-'62 300 cvt. plastic extension for bottom of rear armrest panel. \$70.00set. Flocked black

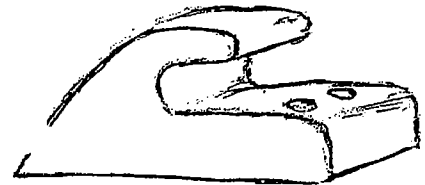

#552 '60-'62 center piece for visor pins \$8.00
A. non-convert.
B. convert

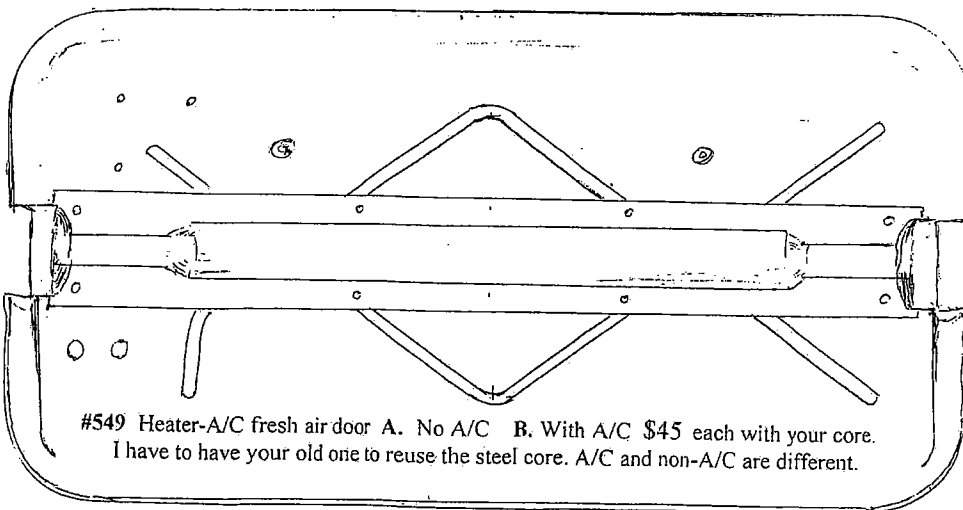

#549 Heater-A/C fresh air door A. No A/C B. With A/C \$45 each with your core. I have to have your old one to reuse the steel core. A/C and non-A/C are different.

#539 '60-'63 300 heel pad rubber inserts. Strip of 4

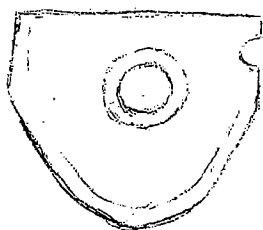
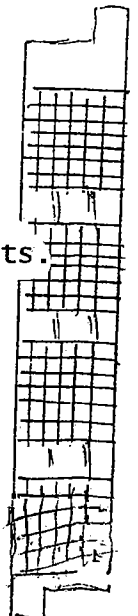

#601 '57-'58 Plymouth manual steering column seal \$12.00

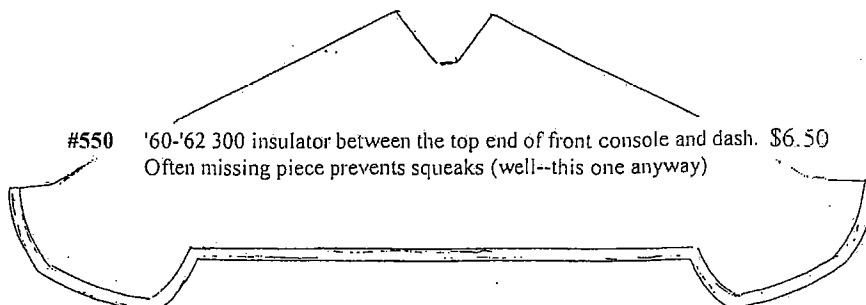

#550 '60-'62 300 insulator between the top end of front console and dash. \$6.50 Often missing piece prevents squeaks (well--this one anyway)

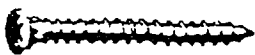

135. Chrome tapping screws

- A. #8 x 1/2" #6 head
- B. #8 x 3/4" #6 head
- C. #8 x 1-1/8" #6 head
- D. #8 x 1-1/2" #6 head
- E. #8 x 1-3/4" #8 head
- F. #8 x 2" #8 head
- G. #8 x 2-1/4" #8 head
- H. #10 x 1/2" #10 head
- I. #10 x 1" #10 head
- J. #10 x 1-1/2" #6 head
- K. #8 x 5/8" #8 head
- L. #8 x 5/8" #6 head
- M. #8 x 1" #8 head
- N. #8 x 1" #6 head



136. Lockwash & Nut

- A. 10-24
- B. 10-32
- C. 1/4 - 20
- D. 5/16 - 18



173 300 F,G,H consol to floor s.s

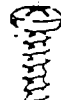

148 Binding head tapping screw '58 - '59 arm rest 14 x 2

176 No.4 S/S screw for stripped holes Push button plate

175 Courtesy Light switch screw s/s

147 1/2 Oval Head Phillips Machine screw
A. 10-24 x 1/2 Glovebox hinge to dash
B. 1/4 - 20 x 3/4 Hemi plug cover and conv. top header to side rail

174 300 F,G,H,Console Compartment Hinge Screws A. 1/2" B. 3/4" S/S

144. Trim Panel Clip

179. Trim panel clip.

155 Special socket head screw for door window handles

DIMMER SWITCHES

D-3 \$9.75

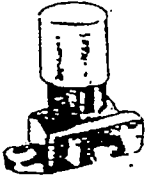

'59-'82

102AA

'57-'59 Dodge and Plymouth steering column base plate gasket.

Don't forget to send gas and brake pedal, column seal cores with your order!

378. '60-'62 Chrys. Pushbutton light shields

379. '63-'64 Chrys pushbutton light shield.

308. Push-on retainer for heater cable ends 3/16" stud size

IGNITION SWITCH

S-2 \$24.30

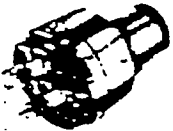

'60-'68 Cars
'61-'81 Dodge truck

S-3 \$18.90

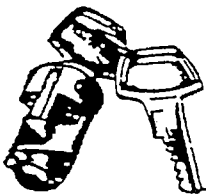

Ignition cylinder and keys for above

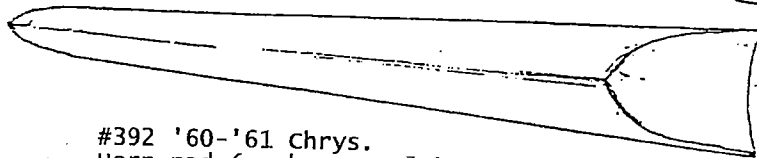

#392 '60-'61 chrys. Horn pad (exchange only) Black-you paint to match



#496

'63-'66 A-body Glovebox snubber

299. '57-'59 all H.T. & conv. front seat back stop

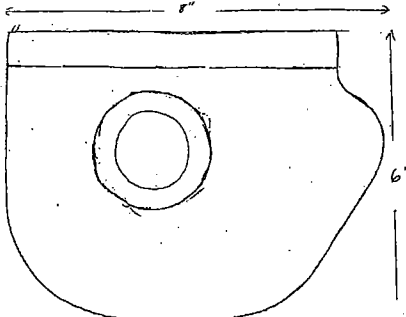

#604 '58-'62 Imp. column aux. seal, see #603 \$12.00

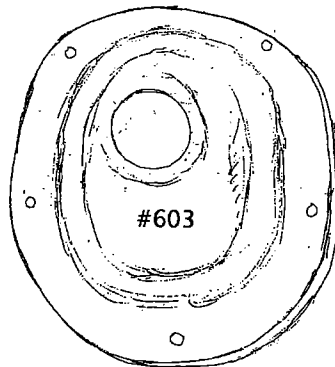

#603

#603 '60-'62 Imp. column sea. Need old one for metal core. see also #604. #29.50

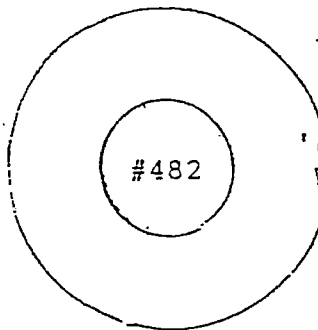

#482

56. Snubbers in pushbutton unit.

'56-'59 torqueflite

57. Powerflite

32. Ash tray snubber '59 & later

6. Glovebox snubber '55-'65

505. Flat head needle

int. sheet metal nail. 12X1/2"

5

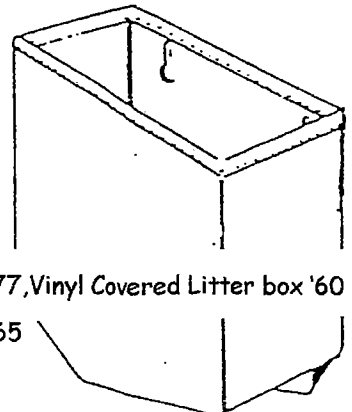

77. Vinyl Covered Litter box '60

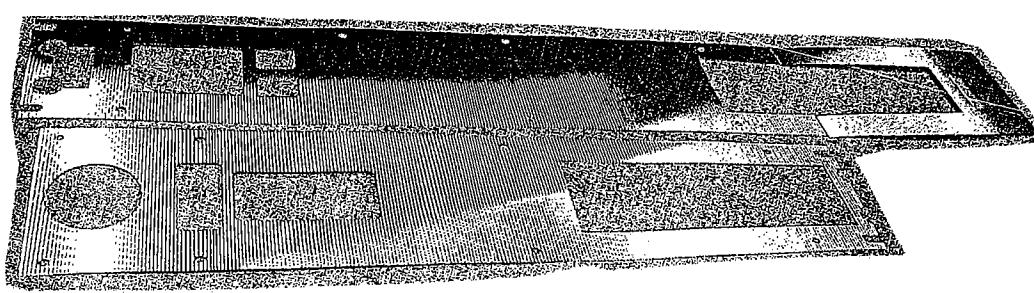

#676 '55-'56 300 console lined aluminum inserts. Beautiful reproductions to replace those impossible to fix originals. Rear is done in two pieces due to material limitations. The two pieces butt together at the rear next to the console compartment. The joint will be unnoticeable. \$300/set fr. & rear.

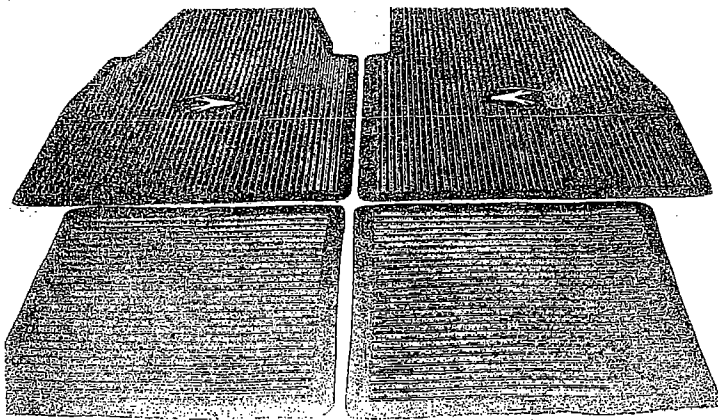

#677

Set of four rubber floor mats. Nice reproduction of late fifties MoPar floor mats. Work fine from '55 and up. Available in black, seafoam green, red. Beige and brick are now only available for fronts, but rears will be available soon. Brown is coming soon. Beautiful authentic finishing touch to your restoration. \$195 set of four

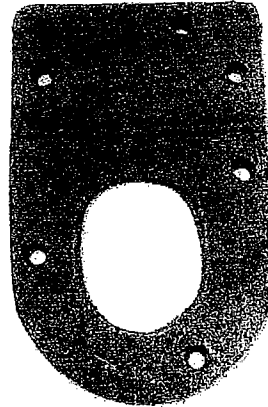
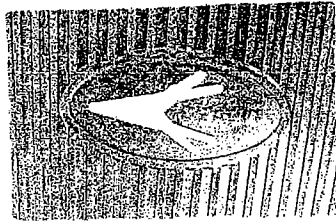

#679 '55-'56 Chrys., Des., Imp. steering column seal. Sandwich construction-waterproof board, jute type pad, thin rubber. Just like original. \$20.00

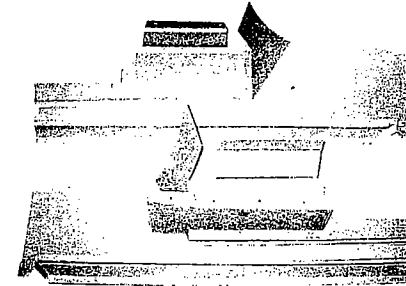

#699

'59-'64 all full size cars. \$32.00 with A/C

Waterproof board backs for heater, A/C plenum under dash. Install with 1/8" all aluminum pop rivets with backing washers on board side. Originals were usually stapled but trying this is likely to break the fiberglass. Also available for non A/C '57-'64

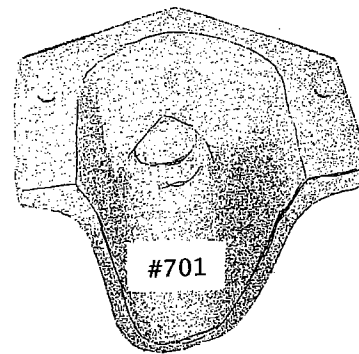

701 '59 Chrysler, DeSoto hand brake cover. The original covers are extremely hard to find due to their fragile thin plastic construction. I took an original and did some "body work" on it to make it about three times as thick as original, sanded, primed, and sanded before pulling a mold from it. The second picture of the back side shows the added thickness and strength. Molded in very hard urethane. It will require light sanding, priming and painting. All the extra thickness was built up on the outside so there is no clearance problem inside. You will love it and it won't break! New bolts included. \$40

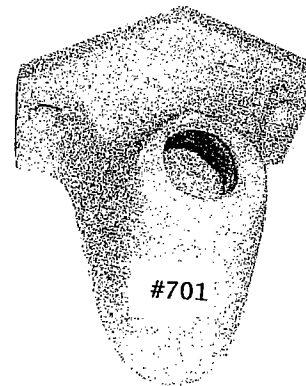

'60 and later park brake release handles molded in very hard (plastic like) urethane

702 Early '60 This piece pushes onto splines on the release arm shaft. Heat the splines to aid in pushing it on without damaging it. \$16

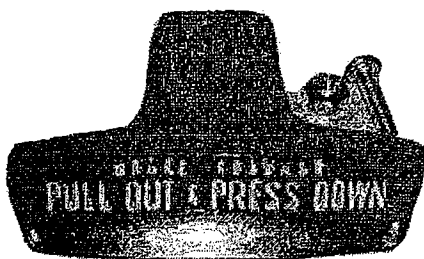

#703 late '60 & later. The originals are easily broken and due to the roll pin holding them on, they break easily trying to take them off and especially trying to install them. I have made the back side thicker & stronger and also incorporated a machine screw and nut for easy installation (included). You will need to enlarge the hole in the shaft very slightly with a 9/64" drill. The back side turned out a bit rough, but the front visible side is great. \$20.00

NOT PICTURED

705 '57-'59 Chrysler, DeSoto manual trans. main column seal. Must have your old core. \$38

706 '57-'59 Chrysler, DeSoto man. trans. secondary column seal. No core required. \$17

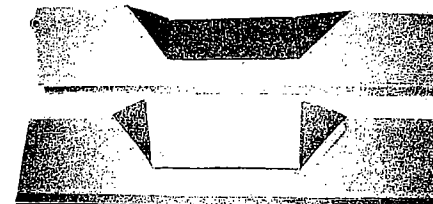

#700

All '57-'58 \$20.00 with A/C



#707 late '60 & later bumper on park brake assembly. takes handle #703

429. SEAT FOAM FOR BUCKET SEATS Beautiful reproductions-- cut from the highest quality "instant Rebound" foam on Specially Designed jigs to match original Contours--backed with burlap and edged with cloth where original. Use with new seat spring "ladders" and restore your seating comfort. Prevents stretching your new upholstery out of shape too. A complete set, fronts and rears, for the '60-'62 Chrysler 300 letter cars Cost \$460. For '60-'64 C-body, and '62-'65 A- and B-body, front bucket seats cost \$240 a pair. Incredibly, all these years and body styles used only two basic seat layout designs-- full insert or partial insert (or A combination of the two). See drawings below. Examples: the '60-'62 letter cars all have full inserts: the '62 300 has partial inserts for the bottoms and backs; the '63 darts have full insert bottoms and partial insert Backs. Shipping for a full Front and rear set or for one or two sets of fronts is oversize 2.

Top Boots

These boots are sewn to original patterns with snaps in place, including hidden snaps where applicable. Colors vary widely and I do my best to match your sample with readily available goods. NOS or reproduction vinyl can be used at extra cost. Other boots can be custom made for comparable prices if you send your old boot. '55-'70 Chrysler, '55-'60 DeSoto, '57-'62 Imperial, '57-'60 Plymouth/Dodge, '63-'66 Dart/Valiant, '68-'70 B-body (with correct hooks), '68-'70 C-body. Pricing ranges from \$235 - \$260 standard vinyl, \$280 - \$330 with NOS or reproduction vinyl. Figure a middle price and I'll adjust on the final bill.

Top Wells

These are sewn to original patterns using readily available Materials closest in color and grain to your sample. NOS or Reproduction vinyl can be used at extra cost. Other wells Can be made at comparable prices if you send your old well. Drains are not included. '55-'70 C-body, '55-'60 DeSoto, '57-'62 Imperial, '57-'60 Plymouth/Dodge, '63-'66 Dart/Valiant. All are priced \$110

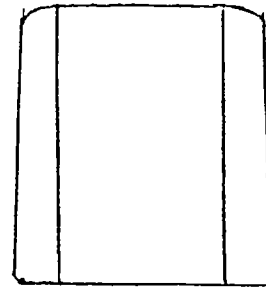

A
FULL BACK

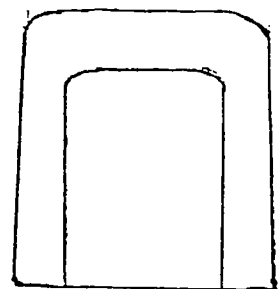

B
PARTIAL BACK

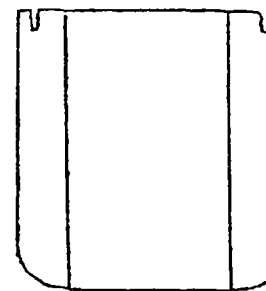

A
FULL BOTTOM

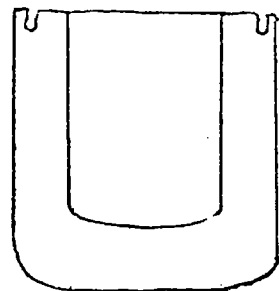

B
PARTIAL BOTTOM

Seat Upholstery Other than 300's

I am now collecting patterns for various popular Chrysler products. I have found extremely close matches in color and grain for many. I now Have patterns for '56-'60 Imperial; '56-'60 Chrysler NY; '57 Desoto FF; '56-'59 Adventurer; '56 Pacesetter convt.; '57-'59 Fury; '59 DeSoto FF & FD; '59 Dodge; '62 Fury; '63-'66 Dart GT; '65-'66 Valiant. ('57-'59 Adventurer And Fury reproduction cloth is done, please ask for separate price sheet). Prices given by quote.

'62 - '65 Uhpolstery -300s--

'62 Non-letter 300 leather seat upholstery kit, Top grain leather sewn to original patterns with stamps in the front backs exactly like the originals. Any Color. Fronts with center armrest \$1250 rears \$1180.

'64 300K seat upholstery Kit. Top grain Leather sewn to the Original patterns. Fronts \$1285 Rears \$1180 Pearl white add \$70.

'65 300L seat upholstery kit. Top grain leather sewn to original patterns. Black fronts \$1265 Rears \$1200 Other colors add \$75. Console Carpet \$60. Floor Carpet (must reuse Heel pads) \$150

'55 - '62 LETTER SERIES 300 Ask For Separate Complete Price sheet.

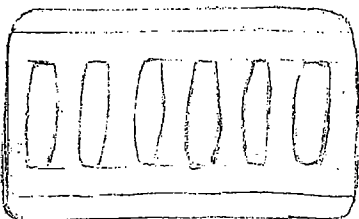

- #608 '64 Chrysler manual transmission clutch pedal.
- A. Brake - molded onto metal \$16.00 need your old core
 - B. Clutch - slip over type \$11.00 no core needed

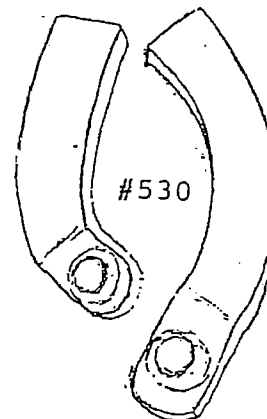
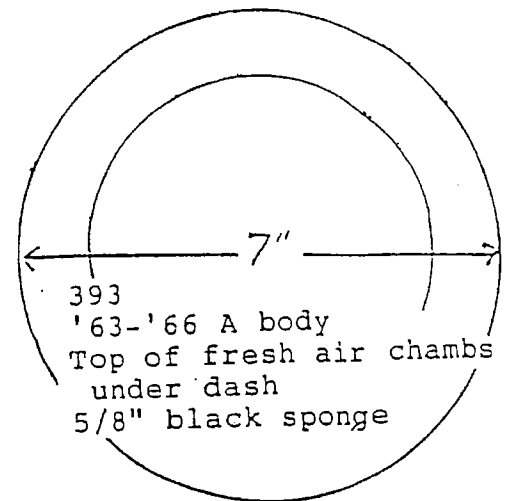

#530 '57-'59 Some front seat back pivot arm cover hard urethane. Neutral color must be painted to match interior. \$90.00 set

Glove boxes

These custom cut reproductions feature scored folds and stapled construction like the originals. The Greatest care was taken to collect Original boxes to make accurate patterns for the Best possible reproductions.

IMPERIAL

GB1*	'55-'56	\$50
GB2*	'57-'59	\$63
GB3*	'60-'63	\$63
GB4*	'64-'66	\$47
GB41	'67-'68	\$43
GB10	'70-'71	\$45

CHRYSLER

GB51	'35 Airstream	\$43
GB30	'37 Airflow	\$45
GB50*	'47	\$43
GB1*	'55-'56	\$50
GB5	'57-'58	\$43
GB6	'59	\$58
GB7A	'60-'61 W/O AC	\$48
GB7B	'60-'61 W/ AC	\$51
GB8A	'62 W/O A/C	\$49
GB8B	'62 W/ AC	\$52
GB9A	'63-'64 W/O AC	\$48
GB9B	'63-'64 W/ AC	\$51
GB55	'65 Chrysler	\$65
(replaces the original molded unit.)		
GB42	'67-'68	\$50
Above replaces molded original		
GB10	'70-'71	\$50

DODGE

GB39*	'51-'52	\$43
GB47	'54	\$43
GB12	'55-'56	\$43
GB13	'57-'58	\$45
GB34	'57-'58 Truck	\$40
GB14	'59	\$45
GB15A	'60-'61 W/O AC	\$48
GB15B	'60-'61 W/ AC	\$51
GB16*	'61-'62 Lancer	\$50
GB33	'63-'64 Dart	\$40
GB17	'64 B-body	\$40
GB18	'65 B-body	\$48
GB19	'66 Polara	\$48
GB52	'67 Polara	\$48
GB20	'66-'67 B-body	\$48
GB21	'67-'72 A-body	\$43
GB22	'68 B-body	\$43
GB23	'69 B-body	\$41
GB24	'69-'72 Monaco	\$43
GB25	'70-'74 E-body	\$49
GB32	'70 B-body	\$43

*These are flocked gray as original.

DESOTO

GB45*	'48	\$47
GB40*	'50	\$45
GB36*	'55-'56	\$45
GB11*	'57-'58	\$47
GB6	'59	\$60
GB15A	'60-'61 W/O AC	\$48
GB15B	'60-'61 W/ AC	\$51

PLYMOUTH

GB35*	'39	\$50
GB48	'46-'48	\$43
GB44	'49	\$43
GB46	'52	\$43
GB43	'55-'56	\$42
GB26	'57-'58	\$44
GB27	'59	\$46
GB38	'60	\$45
GB28	'60-'62 Valiant	\$45
GB29	'61	\$43
GB53	'62 Plymouth	\$50
GB33	'63-'66 Valiant	\$48
GB49	'65 Fury	\$48
GB31	'67 Fury	\$48
GB21	'67-'72 Valiant	\$42
GB21	'67-'69 B'cuda	\$42
GB22	'68 B-body	\$43
GB37	'68 Fury	\$48
GB23	'69 B-body	\$43
GB54	'69-'71 Fury	\$48
GB32	'70 B-body	\$50

FIREWALL PADS

FP1	'55-'56 Chrys. Des. Imp.	\$75
FP2	'57-'58 Chrys. Des. Dodge, Ply.	\$95
FP3	'57-'59 Imperial	\$95
FP4	'59 Chrys.Des.Dodge, Ply.	\$95
FP5	'60 Chrys.Des.Dodge, Ply.	\$95
FP6A	'60 Imp. w/ sewn on rubber skirt	\$95
FP6B	'61-'63 Imp. w/o rubber skirt	\$80
FP7	'61 Chrys.Des.Dodge, Ply.	\$80
FP8	'62-'64 Chrysler	\$75
FP9	'55-'56 Ply.Dodge	\$75
FP10A	'63 A-body manual	\$60
FP10B	'63 A-body automatic	\$60
FP11A	'64-'66 A-body manual	\$60
FP11B	'64-'66 A-body automatic	\$60
('64-'66 state 6 cyl or V8)		

These pads are cut out of heavy duty waterproof panel board with a rubber skirt sewn on where original. Padded with 1" fiberglass and ready to install. See #99 retainers in interior section.

Your car's glovebox or firewall pad not listed? I can work up patterns and make one for comparable prices if you'll send me your old one.

#99 Firewall pad
insulation pad
retainer



DOORS

SIDE GLASS & RELATED PARTS

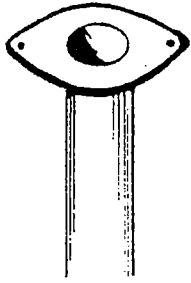

79 Pow window wire loom tube.
A. '64 B '60 - '63

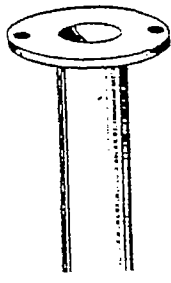

109. Power window wire loom tube
'57-'62 Imperial



35. Power window wire tube '57 - '59
Metal not included



36. Grommet in door hole for #35

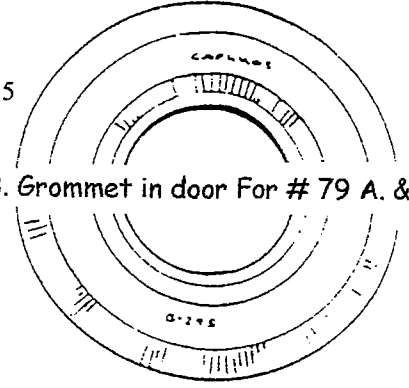

118. Grommet in door For # 79 A. & B.

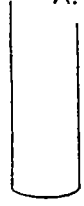

A



B



18. Door snubber '60-'64

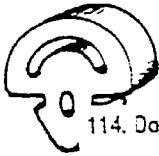

114. Door snubber '65-'68 large cars and later
'60-'68 small cars & later

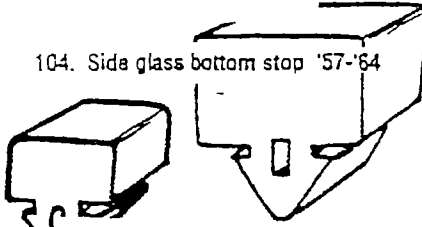

104. Side glass bottom stop '57-'64

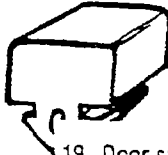

19. Door snubber '60-'64

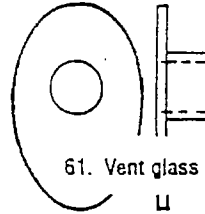

61. Vent glass upper pivot gaskets '57-'64

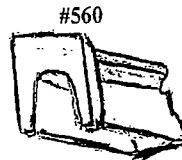

'60 imperial vent frame
upper cushion \$7.20/pair

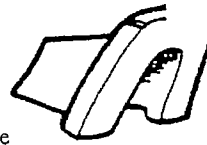

A



B

17. Division bar upper cushion
A. '57-'59 B. '60-'64



37. Lower door hinge seal '57-'59

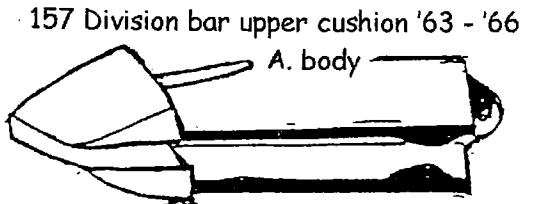

157 Division bar upper cushion '63 - '66
A. body



246. '60 & up
door lock clip



248. '60 & up door handle
ball clip

277. Grommet in door & door post for '61 with
power door locks.

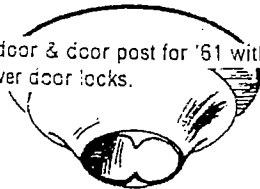

387
Clip--wire rtr.

409
'56 Dod., Ply.
P/W wire loom tube

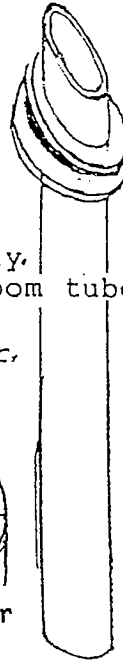

183. '64 Plym.
door bumper

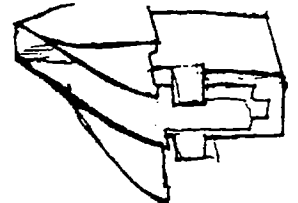

158. Division bar upper cushion '57 - '69 A - body
(can mold w/metal insert if you send old ones)

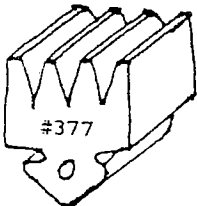

396
'68-'72
Door lock
rod clip

#377 '71 Door bumper
most A,B,E Bodies

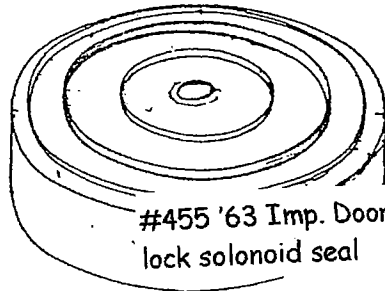

#455 '63 Imp. Door
lock solenoid seal

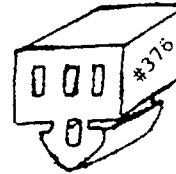

#376 '72-'79
Door bumper
most models

#336 '60-'63 Imp.
Fr. doors on 2dr.,
4dr. & conv.

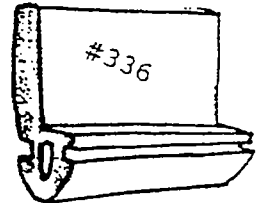

#337 '60-'63 Imp.
Back doors on 4drs

#349 '65-'66 Chrys. Division bar
cushions R&L (exchange only)

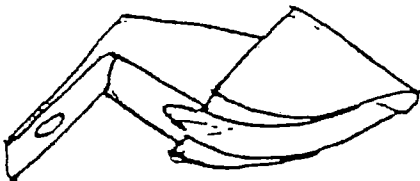

143. Nickel Plated Plug for 3/4 hole
see #92 on page 11



58. Door handle snubber '56, also '57-'62 on
inner arms of handle (some)



31 A. '55 Chrysler & DeSoto
B. '57-'62 Chrysler & DeSoto (see #58)

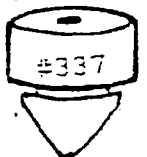



Door Jamb Switch
A. '57-'59 \$6.25
B. '60-'73 \$6.15

391
'50s-60s
12-24x1/2" Phillips oval
head screw w/lock wsh
Attach door latch



384
'69-'70 Clip--door lock
rod end

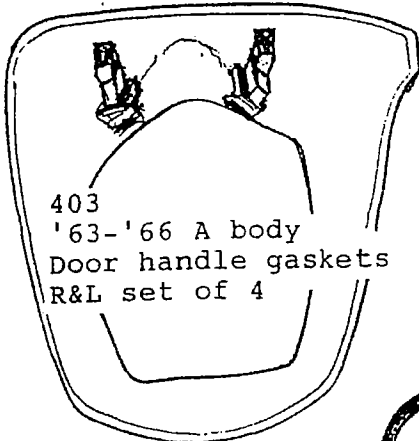

403
'63-'66 A body
Door handle gaskets
R&L set of 4

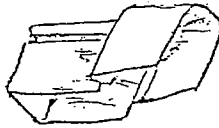

#256 '63 Imp.
Division bar
upper cushion



WINDOW REGULATOR FASTENER

159

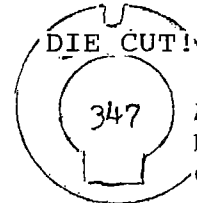

'63-'65
A,B&C-body
Door lock
gasket



'64 Dodge door
hinge pin seal.
Probably fits others.

#423 '66up die-cut nylon
gasket, (see #134 under trunk)
Exc. Dodge 880/ Imperial

↑ USE W20

#514 Rear of rear door
'57-'59 Imperial 4 dr. sedan

#512. Front of rear door
'57-'59 Imperial 4 dr. sedan

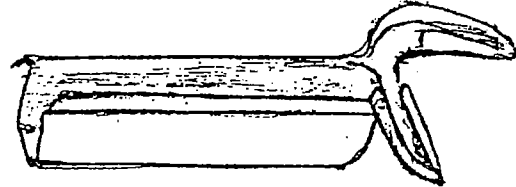

#456 '55-'56 Dodge, Ply.
HT & conv. vent frame to
door seal
(R & L required)

112. Molded w/strip at vent

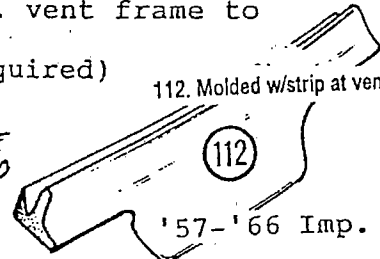

'57-'66 Imp.

39. Molded weather strip at vent '60-'64 Full
size cars

see also #446, #447
bottom of pg. 10

↓ USE W11

#511 '57-'63 Imp.
2drHT & convert.
door w/s end
(4drHT?)

#513 Rear of front door
'57-'59 Imperial 4 dr.
sedan

38.

#38 Molded w/s at vent
'58-'59 exc. Imperial

↓ USE W20

↓ USE W2

↓ USE W20

#515 '60 Imp. convert.
(H.T.?) small sponge
fillers on door jamb by
1/4 window.

#683 '57-'63 Imperial 2 dr
 hardtops & converts. Quarter
 window seal ends for W33
 extrusion. R & L. \$18.00set

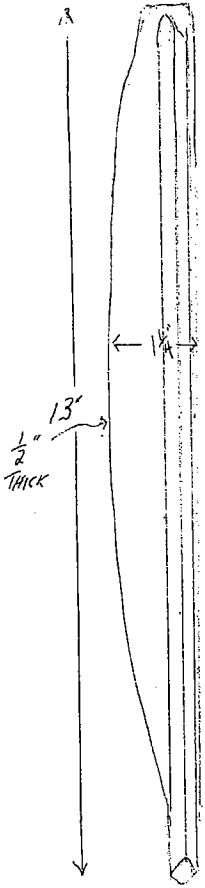

#680 '55-'56 Chrys., Des.
 Imperial HT. Wide molded
 door weatherstrip extension
 on the vent frame. R & L.
 \$18.00set

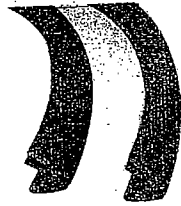

#614 '55-'56 (maybe earlier years) vent
 window seal on division bar. 17"
 long extrusion. \$12.00 pair

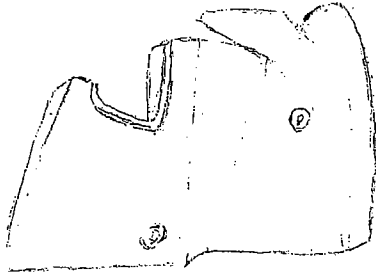

#610 '62 Plymouth gap fillers
 R&L \$29.00 set
 Need old ones for metal core.

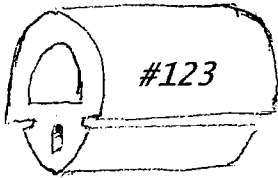

Door snubber
 '78-'79
 possibly '72-'78
 pick-up \$3.00

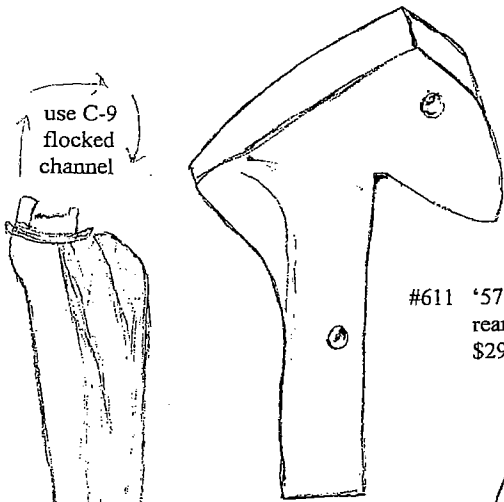

#611 '57-'59 except Imperial, 4 door HT
 rear door weatherstrip end. R&L
 \$29.00 set Need old ones for metal core.

use W11B

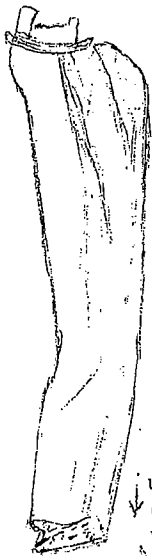

use W-11
 door
 w-strip

#607 '60-'64 station wagon tailgate
 upper corner seal (on body)
 right & left (left pictured) \$20.00 set

'60-'63 Imperial (and probably earlier) 4 door
 molded door weatherstrip ends.

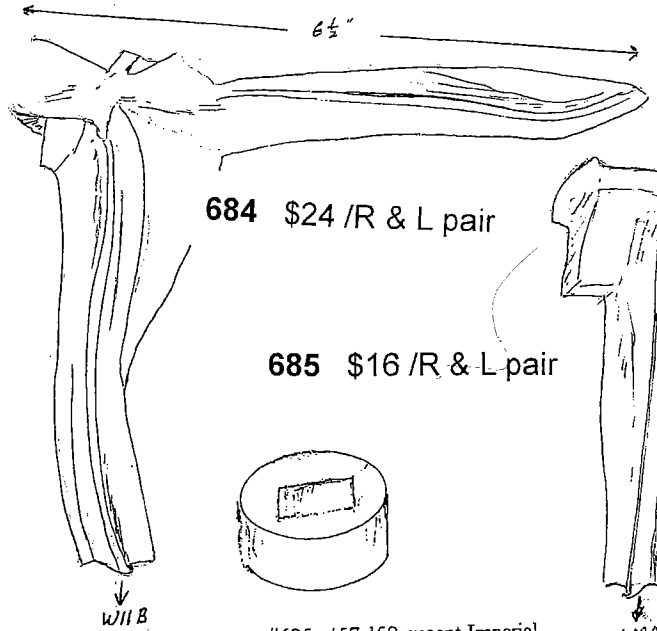

684 \$24 /R & L pair

685 \$16 /R & L pair

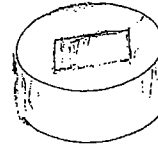

#625 '57-'59 except Imperial
 door stop strap snubber
 \$3.00 each

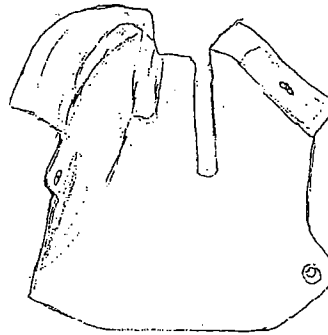

#646
 '63-'66 Dart, Valiant
 2 door HT & convertible
 upper rear of door opening
 filler. Need your old ones
 for steel cores. R+L pair.
 \$30.00 pair

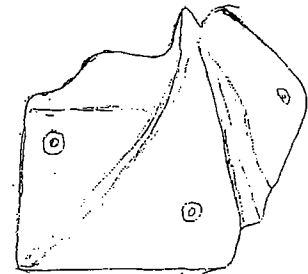

#696
 '64-'66 Imperial 4 door HT
 gap filler. Need your old
 ones for steel cores. R+L pair.
 \$22.00 pair

#612 '57-'59 except Imperial 4 door HT,
 rear door weatherstrip. Molded
 transition piece, R&L \$16.00
 Need old ones for metal cores.

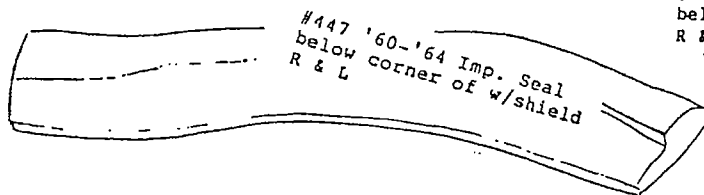
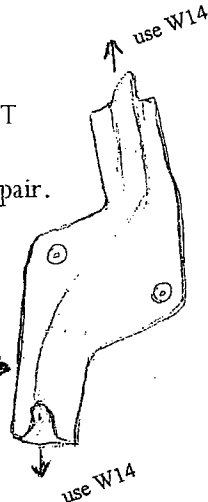

#447 '60-'64 Imp. Seal
 below corner of w/shield
 R & L

#446 '65-'66 Imp. Seal
 below corner of w/shield
 R & L

#489

'55-'56 Chrys., Des.
Imp. All fr. dr.
auxiliary w/strip

117

117. Door post/quarter window gap filler '63,
'64 Chrys. Exchange

127

127. Door post/quarter window gap filler
'60-'62 Exchange

128. Door/window gap filler '60-'62 Chrysler,
DeSoto Large Dodge Exchange (128)

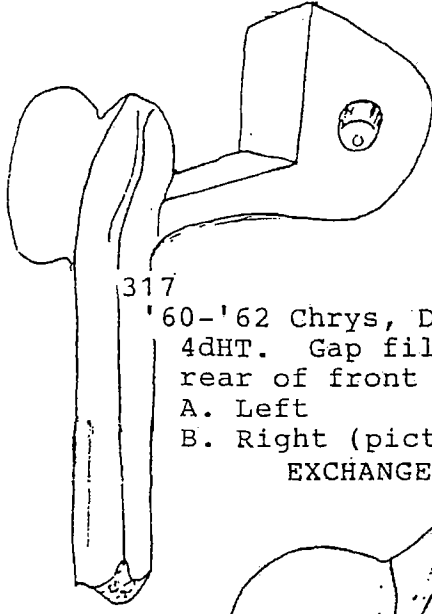

317

'60-'62 Chrys, DeSoto
4dHT. Gap filler at
rear of front door
A. Left
B. Right (pictured)
EXCHANGE

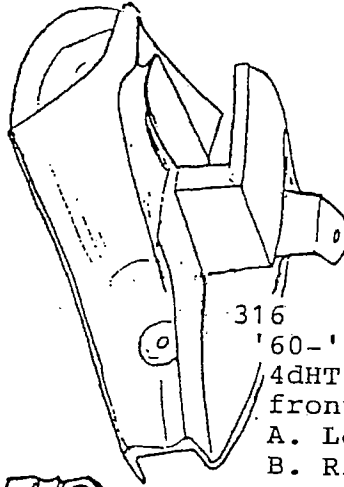

316

'60-'62 Chrys, DeSoto
4dHT. Gap filler at
front of back door.
A. Left (pictured)
B. Right EXCHANGE

#487

R & L

Auxiliary dr.
w/strip
'57-'63 Imp.
all fr. dr.

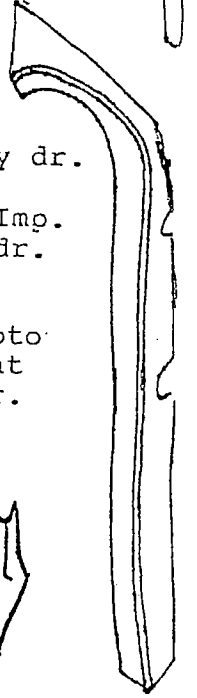

312

'55-'56 Door weather-
strip ends. R&L

'60-'62 Chrys, DeSoto
4dHT. Gap filler at
rear of back door.
A. Left (pictured)
B. Right

EXCHANGE

318

#484

R & L

'57-'59 all 2dr.
& conv. exc. Imp.
door w/strip end
latch side

370 '68-'70 B-Body
door lock pillar seals,
molded with steel cores.
R & L

116. Door/window gap filler '63, '64 Chrys.
Exchange only

116

359 '57-'59 Imp.
convt. Door w-strip
end at top of vent
frame. R & L

#441 '64-'66 Imp.
Quarter gap filler
R & L (L pictured)
Exchange

#442 '64-'66 Imp. gap
filler R & L (L picture)
Exchange

369 '68-'70 B-Body door
jamb seal. Molded w/ steel
cores.

441 & 442 are for
2 dr. hardtop & convt.

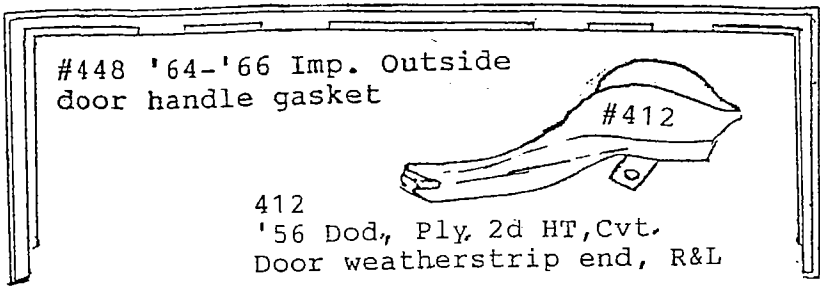

#448 '64-'66 Imp. Outside door handle gasket

412
'56 Dod, Ply. 2d HT, Cvt.
Door weatherstrip end, R&L

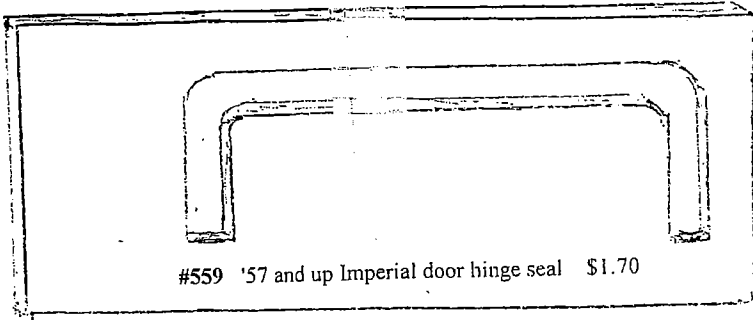

#559 '57 and up Imperial door hinge seal \$1.70

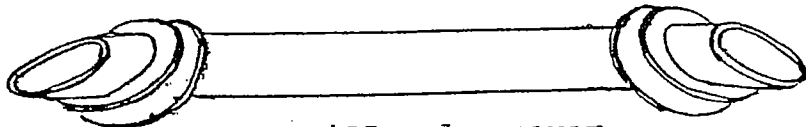

#454 '55 Dodge power window wireloom tube



#509 Stainless steel screws for upper vent window pivot '57-'64 .35 each

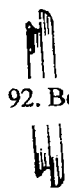

92. Body plug door '57-'59 3/4" hole

See #143 Page 8

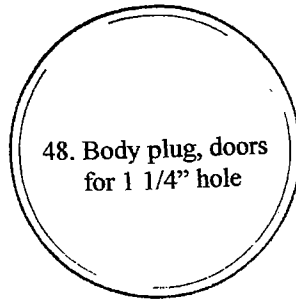

48. Body plug, doors for 1 1/4" hole

'57-'58 Dodge truck molded section of door weatherstrip \$14.00/set

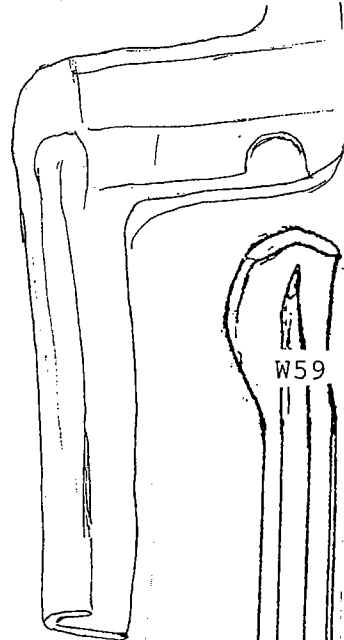

#562
W59 R&L '66-'70 B-body Conv. aux. seal on w/s post \$15.00each

DOOR WEATHERSTRIP

W21	'50s All lower door flange	\$1.70ft
W2	'55-'56 All front dr frame	\$1.45ft
W14	'55-'64 except '57 & up Imp. & A + B Bodies	\$2.05ft
W20	'65-'73 Including sedans	\$2.10ft
W20	'57 & up Imperial	\$2.10ft
W101	'68-'71 B-body w/clp&ends	\$115set
W102	'70-'74 E-body w/clp&ends	\$115set
W11	'50-'70 General purpose (flatter profile than W20)	\$2.15ft
W1	Early A & B-bodies. Also see snap-on type in colors on Pg.5 windlacing.	

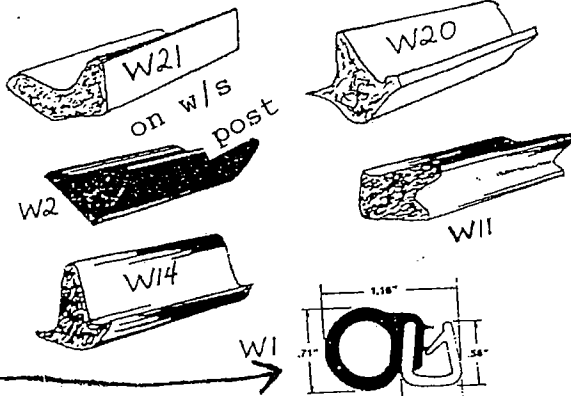

Edge trim and seal black only \$48.00 25ft roll

Chrysler style windlace-weatherstrip combo is no longer available, either original or cloth reproduction. I still have some colors in cloth which resembles a soft close-weave canvas. I need a color sample for best match. Price is \$15.00 yard. (See W1 on this page for drawing)

QUARTER WINDOW WEATHERSTRIP

W99	'53-'54	\$35pr
W22	'55-'56	\$35pr
W22F	(flocked)	\$45pr
W17	'57-'59 Except Imperial	\$35pr
W17F	(Flocked)	\$45pr
W33	'57&up Imperial w/o ends	\$24pr
W19	'60-'62 C-body	\$24pr
W31	'65&up C-body	\$24pr
W23F	'63-'66 A-body flocked	\$45pr
W126	'62-'66 B-body flocked	\$45pr
	'63-'64 C-body flocked	\$45pr
	'64-'66 Imperial	\$45pr

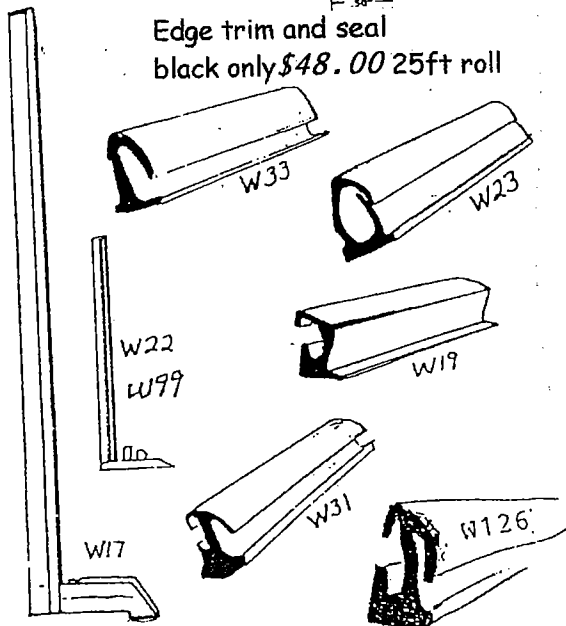

FLEXIBLE FLOCKED CHANNEL LINING

GLASS RUN CHANNELS

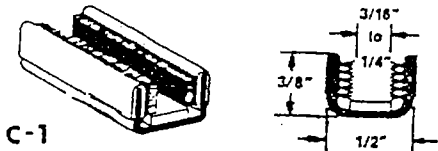

C-1
'55 - '56 division bar \$9.50 Each

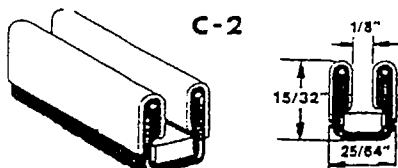

C-2
'55 - '59 Hts and Convs inside front doors \$11.75 Each

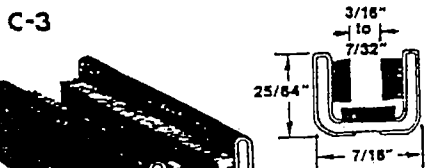

C-3
'57 - '59 Division bar \$10.25 Each

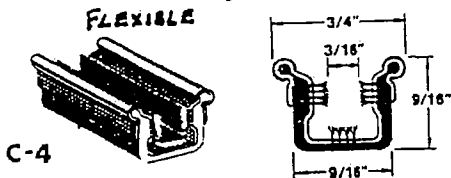

C-4
'55 - '56 4dr. Closed models front & rear \$24.00 Each 96"

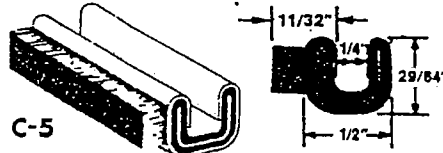

C-5
'55 - '56 SW tailgate \$24.00 Each

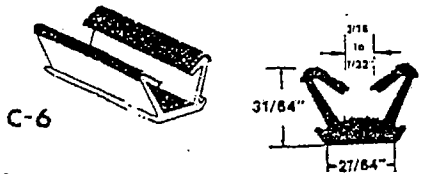

C-6
Division bar B - body 4dr sedan 96" all models \$14.00 Each

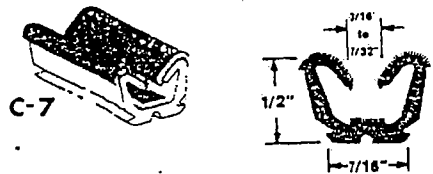

C-7
'60 -'62 Valiant/Lancer closed models \$14.00 Each 96"

C-9 '65 channel and division bar
FR-dr, rr-dr. Qtr-window
96" \$18.00

C-9 '66 - '67 Rear-door. Channel
complete 96" \$18.00

C-10 '60 cars replacement - sedans
96" \$18.00

W110 '64 up Only available inner
belt weatherstrip with
stainless top edge
72" \$19.25

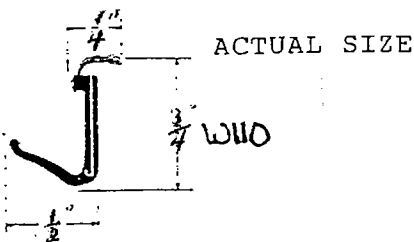

ACTUAL SIZE

W110



W120 '57-'59 rear side
glass setting rubber
\$16.00 each



W121 Late '55 - '56, '57 -'59
all door glass bottom
Channel rubber \$10.25 Each



W122 Early '55 door glass
bottom channel Rubber
\$11.25 Each

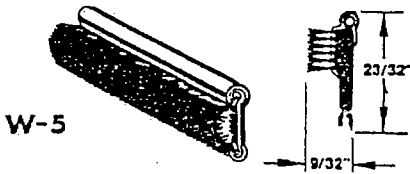

W-5
'55-'63 most inner & outer,
state length \$8.75 / panel.

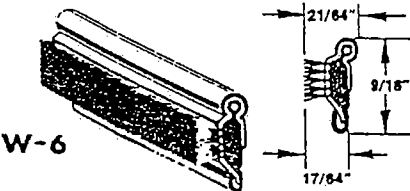

W-6
'61-'66 small cars, '64 some big
cars, state length \$8.75 / panel.



W-7
'53-'56 outer,
state length \$7.50 / panel

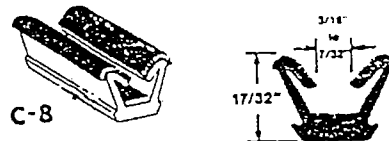

C-8
'63 '68 Dart/Valiant
division bar \$12.50/96"

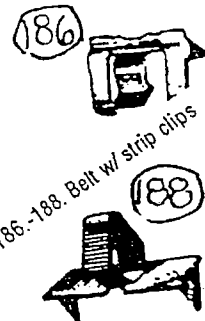
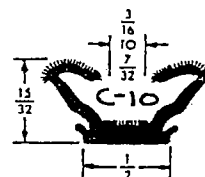
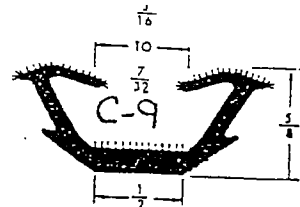

186 -188. Belt w/ strip clips

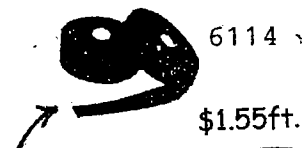

MOHAIR CHANNEL LINER
is a black mohair
lining material with
rubberized backing.
Apply adhesive to back
of liner and bond to
badly worn division
bars and channels.

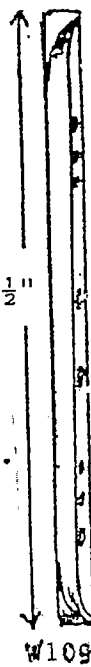

'65-'66 Dart ht & conv.
Also B-body. Auxillary
door seal on vent frame.
Slightly different than
'63-'64, but will fit &
work. \$5.50 Each W109

'57-'59 STATION WAGON AND 4 DOOR SEDAN PARTS

'63-'66 A-BODY
STATION WAGON

NOTE: Due to the extremely limited market for station wagon rubber, the tailgate and door weatherstrips are made up from a combination of several different sponge extrusions super-glued together. W133 and W134 were specifically made for station wagons. My '59 DeSoto wagon with aluminum window frames was the source of samples for the molded parts.

Some weatherstrip items listed have been simplified to work better. I'll refund the difference--They're cheaper!

- Tailgate inner belt weatherstrip. (4ft pc.) \$7.85ea.
- Front door division bar. (C3) \$10.25ea.
- Front door glass top and rear channel. (C11A-60"pc) \$14.75ea.
- Rear door glass channel. (C11B-96"pc) \$22.75ea.
- Tailgate glass upper channel-in body. (C12K-1x60"pc; 2x15"pcs) \$23.00
- Tailgate glass lower channel-in tailgate. (C13K-2x18"pcs)
- Tailgate glass bottom frame setting tape. ES15116 \$12.30
(Can also be used to set top and sides stainless frame.)

- W115K Front door weatherstrip kit. (Does not include molded parts--see #436, #437) (Right and left) \$35.00ea

- W116K Rear door weatherstrip kit. (Does not include molded parts--see #438) (Right and left) \$35.00ea

W52B. Chrome plastic lockstrip used with W130. Enough for one side. \$18.00



W130 \$65
'63-'66 A-body SW. Rear side glass seal--enough for one side.

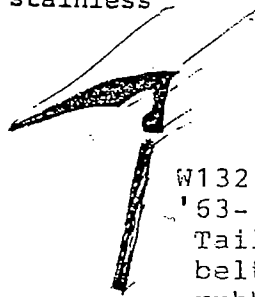

W132 \$23
'63-'66 A-body StWgn Tailgate window outer belt w/s (Extra flat rubber strip included for window to metal gasket)

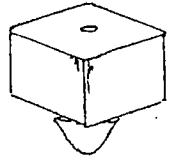

#520
'63-'66 A-body SW tailgate bumper

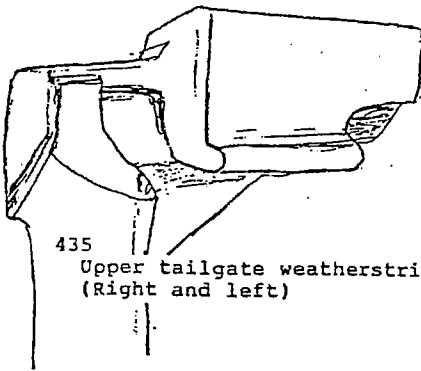

435 Upper tailgate weatherstrip end (Right and left)

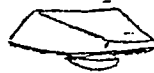

434 Bumper on inside tailgate handle

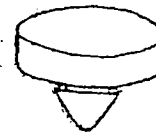

432 Tailgate-to-body bumper. 2 req'd

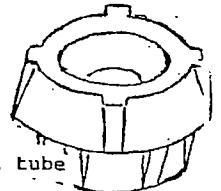

433 Tailgate power window wire loom tube 2 req'd--body and tailgate

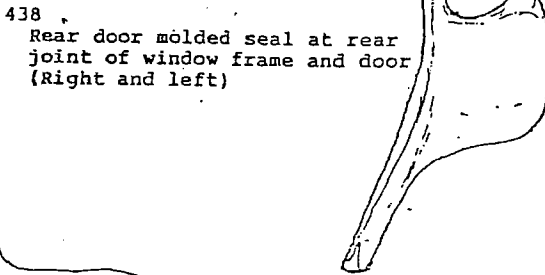

438 Rear door molded seal at rear joint of window frame and door (Right and left)

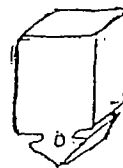

439 Front door bumper

#W133 Tailgate window Outer belt w/strip \$18.00ea



#W134 Rear side glass setting rubber \$26.00ea

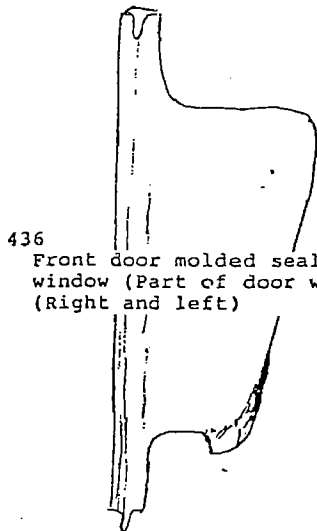

436 Front door molded seal at vent window (Part of door w/s) (Right and left)

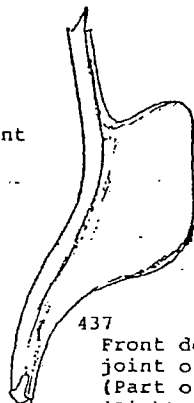

437 Front door molded seal at rear joint of window frame and door (Part of door w/s) (Right and left)

W114K Tailgate weatherstrip w/o ends (See #435) \$40.00

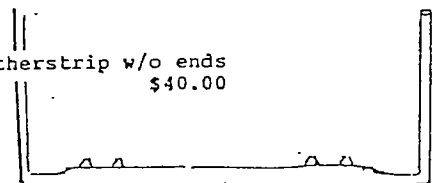

TRUNK

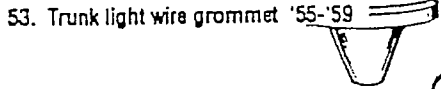
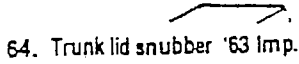
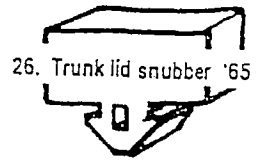
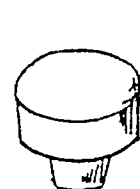
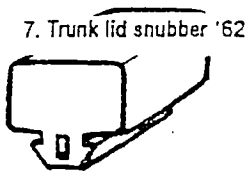
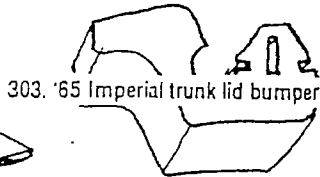
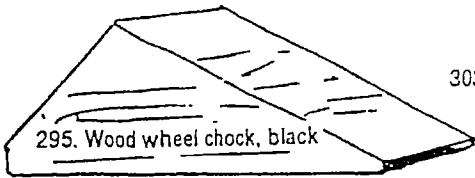

280. Trunk snubber, '55 Dodge

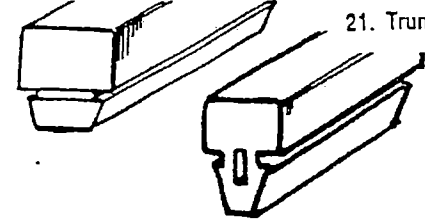
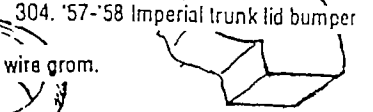

21. Trunk lid snubber '60-'61



207. '60 & later fuel sender wire grom.

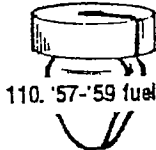

110. '57-'59 fuel gauge wire grommet

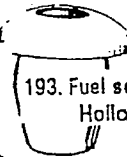

193. Fuel sender wire grommet '57-'59 Hollow. see #110 for solid

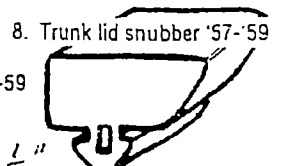

8. Trunk lid snubber '57-'59

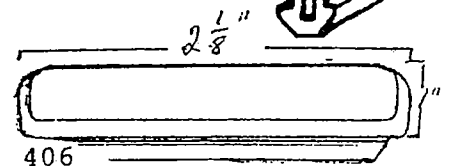
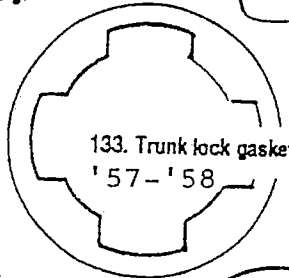
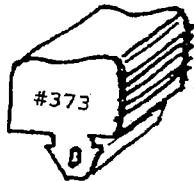
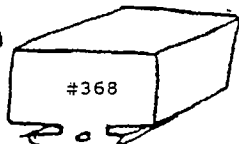
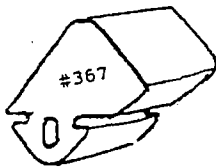

406 '63-'66 A body Trunk body plug Rectangular--2 per trunk

#367/#368 '61 Imp. trunk lid bumpers. (also see #64)

#373 '63 Belvedere '64 Polara, trunk

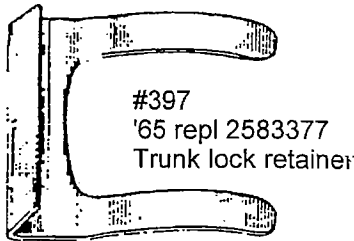

#397 '65 repl 2583377 Trunk lock retainer

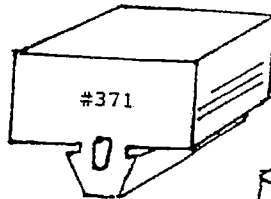

#371 '66-'74 B-Body Trunk lid bumper.

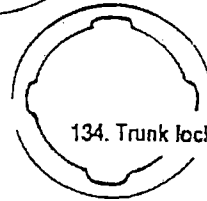

134. Trunk lock gasket '59-'64

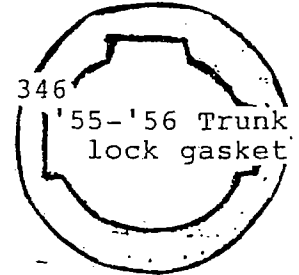

346 '55-'56 Trunk lock gasket

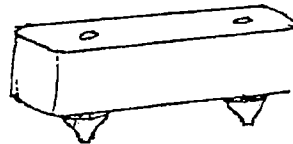

#445 '67 Imp. trunk snubber

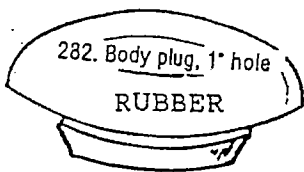

282. Body plug, 1" hole RUBBER

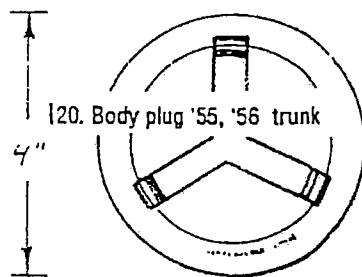

120. Body plug '55, '56 trunk

W106

Rubber edging (actual size)

Goes around edge of metal spare tire cover '57-'62. Many general uses see #W107 \$1.70/ft



'56-'57 Chrys., Des. trunk snubber (see #8 for some '57)

TRUNK WEATHERSTRIP

W8	'55-'56 All makes	\$46
W9	'57-'59 All makes	\$48
W10	'60-'63 Imperial	\$48
	'60-'62 All except A & B body	

(W10- Chrysler changed from a solid sponge seal to a hollow one in '62. After years of failures in getting a solid sponge seal that would consistently work, I've switched entirely to this hollow seal. It works great on all '60-'62.)

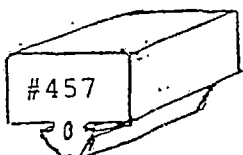

#457 '63-'66 A-Body trunk lid snubber

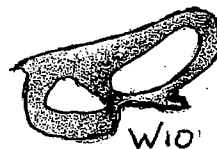
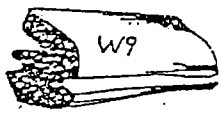

MORE ON NEXT PAGE

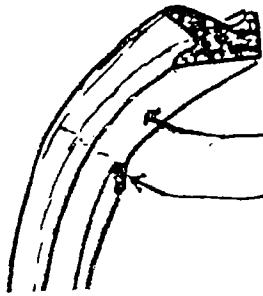

TRUNK WEATHERSTRIP

See bottom of previous page for '55-'62 listings.

TRUNK SEALS
 One piece seals with two
 different profiles as original
 \$34 Each

- TS1 '63-'66 Dart, Valiant
- TS2 '63-'65 Dodge, Plymouth B-body
- TS3 '63-'64 Chrysler
- TS4 '64-'66 Imperial
- TS5 '65-'66 Chrysler, Dodge,
Plymouth C-body
- TS6 '66-'67 Dodge, Plymouth B-body
- TS7 '66-'67 Dodge Charger
- TS18 '66 Barracuda
- TS8 '67-'69 Barracuda Fastback

- TS15 '67-'68 Chrysler, Plymouth,
Dodge C-body
- TS10 '67-'68 Imperial
- TS9 '67-'70 Dart, Valiant
- TS12 '68-'70 Plymouth B-body
- TS11 '68-'70 Dodge B-body
- TS13 '68-'70 Charger
- TS14 '69-'70 Chrysler, Plymouth,
Dodge C-body
- TS16 '69-'70 Imperial
- TS17 '70 E-body

#375 Early '70 trunk seal
 A & B-body, Sponge seal
 made like original. Compare
 yours to illustration.

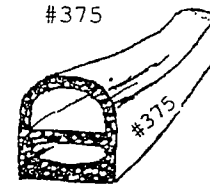

TRUNK CARPETS

Cut, sewn and edged as original. Notches for some latches. Braces, spare tire hold down, and jack hold down not cut out. For '55-'61 carpets are gray cut pile custom manufactured to match original. This is not original texture for '55-'56. To my knowledge no one has ever found any original material. For '61-'62 Chrysler, carpets are black cut pile. Custom designed to replace original rubber mat. For '63-'64 Chrysler, & '64 Imperial, carpets are synthetic felt-like material that resembles original. For '65-up Chrysler, carpets are black loop pile.

IMPERIAL

TC1	'55	\$120
TC2	'56	\$120
TC12	'57-'59	\$95
TC13	'60-'61	\$105
TC14	'62	\$90
TC15	'63 Gray	\$110
TC25	'63 Gray/black	\$125
Loop like original		
TC16	'64	\$90
TC17	'65-'66 w/pad	\$110
TC27	'67-'68 w/pad	\$107
TC22	'73 w/pad	\$110

CHRYSLER/DESOTO

TC1	'55	\$120
TC2	'56	\$120
TC3	'57-'59	\$90
TC4	'60-'61 Gray	\$90
TC5	'61 Black	\$87
TC6	'62 Black	\$87
TC7	'63-'64	\$90
TC8	'63-'64 convt.	\$87
TC9	'65	\$95
TC29	'66	\$90
TC10	'67-'68	\$90
TC11	'69-'72 (includes pad)	\$110

PLYMOUTH

DODGE		
TC19	'55	\$90
TC30	'56	\$90
TC20	'57-'59 Gray	\$90
TC18	'57-'59 Black	\$87
TC4	'60-'61 Gray	\$90
TC32	'60-'61 Black	\$87
CHRYSLER/DESOTO		
TC34	'55-'56 Black loop pile	\$90
TC33	'55-'56 Gray cut pile	\$90
TC20	'57-'59 Gray	\$90
TC18	'57-'59 Black	\$87
TC4	'60-'61 Gray	\$90
TC32	'60-'61 Black	\$87

SPARE TIRE COVERS TO MATCH TRUNK CARPETS

TC27	'55-'56	\$55
TC28	'57 and up (gray or blk)	\$58
TC31	'63 Imp. (gray/blk loop)	\$68

TRUNK PANELS

Custom cut from original patterns, scored and edged as original, ready to install. Set includes right and left side quarter, panels wrapped around trunk hinge and wheelwell area, panel behind rear seat, and panels under rear lip where original. Generally Chrysler panels are gray until '61, then black; Imperial panels are gray until '63, then black. Dodge and Plymouth panels are all gray. Exceptions to these colors are '61 Chrysler which could have either black or gray and '57 Dodge which could also have tan. This may also be true for '57 Plymouth, but I'm not sure.

PLEASE NOTE: Shipping size on almost all trunk panels sets is oversize II. It is much more cost effective to ship all large items in the same box such as firewall pads, rear decks, carpets, etc. Also see trunk carpets on previous page and jack instruction sheets on page 19.

CHRYSLER/DESOTO

TP1	'55	\$97
TP2	'55 Conv.	\$87
TP3	'56	\$97
TP4	'56 Conv.	\$87
TP5	'57-'59	\$97
TP6	'57-'59 Conv.	\$87
TP7	'60	\$95
TP8	'60 Conv.	\$95
TP9	'61 blk or gray	\$95
TP10	'61 Cvt. blk/gr.	\$95
TP11	'62	\$95
TP12	'62 Conv.	\$95
('60-'62 300 letter car series HT are \$8 less-no divider board)		
TP13	'63-'64	\$97
TP14	'63 Conv.	\$97
TP15	'64 Conv.	\$97
TP16	'65	\$97
TP24	'66	\$97
TP17	'65-'66 Conv.	\$95
TP18	'67-'68	\$93
TP19	'69-'72	\$105

IMPERIAL

TP20	'55 4 dr.	\$97
TP60	'55 2 dr.	\$97
TP3	'56 4 dr.	\$97
TP61	'56 2 dr.	\$97
TP21	'57-'59	\$97
TP22	'57-'59 Conv.	\$97
TP23	'60-'61	\$95
TP60	'60-'61 Conv	\$95
TP25	'62	\$102
TP44	'62 Conv.	\$102
TP26	'63	\$97
TP45	'63 Conv.	\$97
TP27	'64-'66	\$100
TP28	'64-'66 Conv.	\$95
TP29	'67-'68	\$105
TP59	'67-'68 Conv.	\$105
TP43	'69-'72	\$105
TP57	'73	\$105
'67-'73 Panels include right side masonite panel.		

DODGE

TP50	'55	\$97
TP64	'55 Conv.	\$89
TP47	'56	\$97
TP65	'56 Conv.	\$89
(All '55 & '56 are speckled gray)		
TP37	'57-'58 gray	\$97
TP38	'57-'58 Conv.	\$89
TP39	'59	\$92
TP40	'59 Conv.	\$85
TP41	'60	\$91
TP49	'60 Conv.	\$87
TP53B	'62 B-body	\$87
TP42	'63 Dodge B-body	\$87
TP11	'63-'64 880	\$95
*TP56	'64-'65 B-body	\$52

PLYMOUTH

TP62	'55	\$95
TP63	'55 Conv.	\$86
TP30	'56	\$95
TP46	'56 Conv.	\$86
TP31	'57-'58	\$97
TP32	'57-'58 Conv.	\$87
TP33	'59	\$91
TP34	'59 Conv.	\$83
TP58	'60	\$91
TP55	'60 Conv.	\$86
TP35	'61	\$91
TP53A	'62	\$87
TP54	'62 Conv.	\$82
*TP56	'63-'65 B-body	\$52

*Masonite filler piece from quarter panel to trunk floor-state year-there are differences.

I can no longer be sure to supply snap in buttons with trunk panel sets. They are now obsolete! Save your Originals!

JACK INSTRUCTION SHEETS

Each one has been painstakingly recreated from the original. They are all printed accurately and clearly on the correct paper for each particular car. Complete your restoration with these high quality reproductions. I have recently finished many '55-'59 sheets. Be aware that during these years there were only DeSoto sheets. I have never seen, or met anyone who has seen, any other than DeSoto. Over 20 years ago I changed DeSoto sheets to make '57-'59 Chrysler sheets. Now I have completed the collection. Anyone else selling these sheets without buying them from me simply stole my artwork. Not original, but sure looks good ! ALL \$5.00 Each

J44 '55 DeSoto	J2 '58 Chrysler	J19 '62 Dodge
J26 '55 Chrysler	J11 '58 DeSoto	J53 '62 Imperial
J31 '55 Plymouth	J3 '59 Chrysler	J55 '62 Plymouth
J32 '55 Dodge	J17 '59 Imperial	J54 '63 Imperial
J34 '56 Imperial	J20 '59 Plymouth	J7 '63-'64 Chrysler
J35 '56 Plymouth	J43 '59 Dodge	J23 '63-'64 Dodge/Plymouth
J36 '56 Dodge	J12 '59 DeSoto	J21 '63-'64 Valiant
J13 '56 Chrysler	J4 '60 Chrysler/ DeSoto	J22 '64 Imperial
J14 '56 DeSoto	J56 '60 Chrysler Sta. Wag.	J24 '64 Valiant
J37 '57 Imperial	J16 '60 Dodge	J8 '65 Chrysler/Dodge C-body
J38 '57 Plymouth	J18 '60 Imperial	J58 '65 Plymouth C-body
J39 '57 Dodge	J68 '60 Plymouth	J27 '65 B-body
J1 '57 Chrysler	J59 '61 Chrysler Station Wagon	J25 '65-'66 Dart
J10 '57 DeSoto	J5 '61 Chrysler/DeSoto	J30 '65-'66 Imperial w/o chart
J40 '58 Imperial	J15 '61 Plymouth	J30b '66 Imperial w/ tire psi. & load chart
J41 '58 Plymouth	J52 '61 Imperial	J29 '66 Chrysler/Dodge
J42 '58 Dodge	J6 '62 Chrysler	J50 '66 A-body
		J9 Sure Grip Instructions

UNDER HOOD

HOOD PADS

HP38 '55, '56 Chrys., Des. \$20		
HP1 '57-'59 Chrysler/DeSoto \$20	HP9 '63-'64 Chrysler \$25	HP19 '66 Chrysler/Dodge, \$25 C-body
HP6 '57-'58 Imperial \$20	HP10 '63-'64 Dart \$25	HP33 '66 Dodge B-body \$25
HP2 '57-'58 Dodge \$20	HP11 '63 Plymouth \$25	HP20 '66 Dart \$25
HP38 '59 Dodge \$22	HP12 '64 Dodge Polara \$25	HP21 '66 Valiant \$25
HP3 '57-'59 Plymouth \$20	HP13 '64 Plymouth B-body \$25	HP22 '67-'68 Chrysler \$25
HP4 '60 Chrysler/DeSoto \$20	HP13 '65 Plymouth B-body \$25	HP29 '67-'68 Imperial \$25
HP5 '60 Imperial \$20	HP14 '64-'65 Imperial \$25	HP32 '67-'69 Dart \$25
HP30 '60 Dodge \$20	HP15 '64-'65 Valiant \$25	HP36 '68 Dodge B-body \$25
HP18 '60 Plymouth \$20	HP16 '65 Chrysler/Dodge \$25	HP23 '69-'72 Chrysler \$25
HP31 '60-'62 Lancer \$20	C-body	HP24 '69-'72 Imperial \$25
HP8 '61-'62 Chrysler / DeS. \$25	HP35 '65 Dodge B-body \$25	HP25 '73-'75 Imperial \$25
HP37 '61 Plymouth \$25	HP17 '65 Dart \$25	HP26 '74 Dart/Valiant \$25
HP7 '61-'63 Imperial \$25	HP18 '65 Plymouth C-body \$25	HP27 '75 Chrysler \$25
	HP18 '66 Plymouth C-body \$25	HP28 '75-'79 Cordoba \$25

These pads are all cut out of 1/2" fiberglass with a scuff resistant coating on the outside. Holes punched where original for clips. Others without clip holes were glued on with contact cement. SEE NEXT PAGE FOR CLIPS.

192. '60 Chrys. trunk drain tubes
 A. Rear edge of trunk opening
 B. Center of lid to rear edge

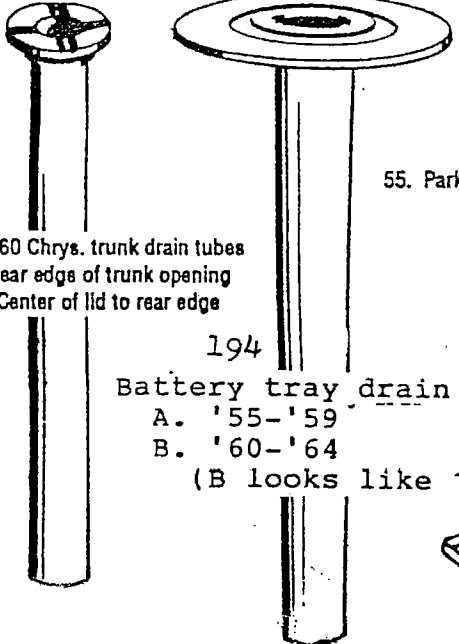

194

Battery tray drain tube

A. '55-'59

B. '60-'64

(B looks like 192) 34

55. Parking brake cable insulator '55-'59

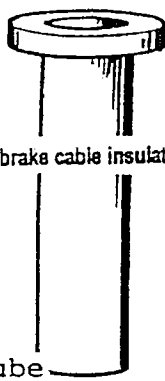

78. Tubing & wire ties, nylon



93. Blower motor cooling tube '57, '58

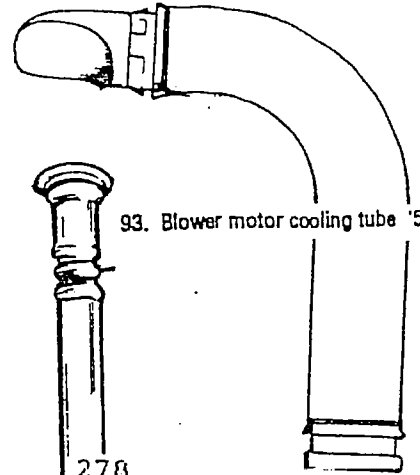

278

'59-'64 All makes
 A/C case drain tube

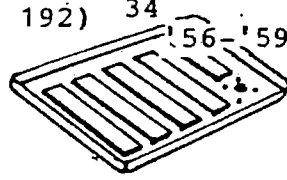

'56-'59 Battery tray

A. Large

B. Small

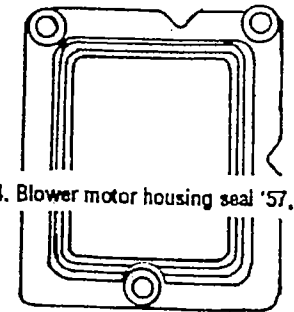

124. Blower motor housing seal '57, '58

241. P/S pump-gen. drive '56 & older

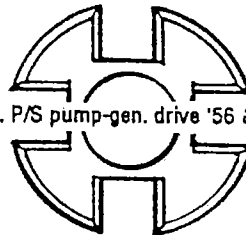

131. Heater control valve seal

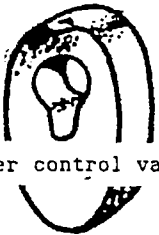

'55-'56

130. Heater control valve seal '57, '58

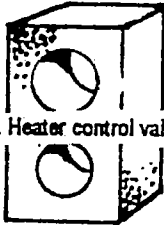

245. Heater core outlet seal

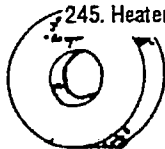

24. Steering shaft insulator

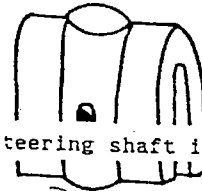

A. '55-'57
 B. '58-'64

119. '57 300 C air cleaner brackets

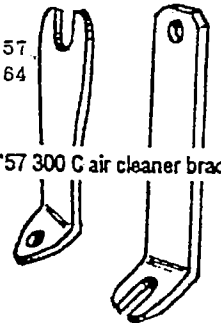

#101 Wire type hose clamps

- A. 392 bypass hose 1" I.D.
- B. Gas hose 5/16" I.D.
- C. Brake booster hose 15/32 I.D.
- D. Heater hose 5/8" I.D.
- E. P/S return hose 5/8" I.D.
- F. 1 1/2" I.D. Upper radiator
- G. 1 3/4" I.D. Lower radiator
- H. 2" I.D. Lower radiator
- I. early 318 C.I. bypass hose
- J. For 3/8 I.D. booster hose

255. '60 & up "floating" P/S pump bumper

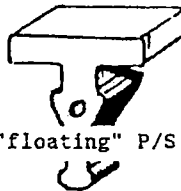

243. 1/8" x 1/8" tube connector



242. 1/8" x 1/8" x 3/10" plastic tee

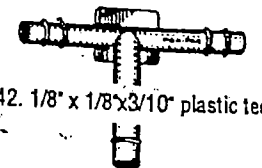

#338 Fan shroud snubber
 '56 Chrys., Desoto



#493

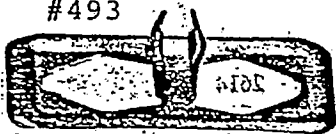

'63 & newer hood
 pad clip. Black
 finish.

415

'60-'66 A body, 6 cyl
 Accel rod insulator, grn

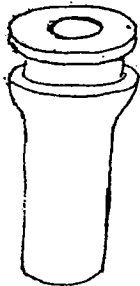

290. Black plastic hood pad fastener
 General purpose replacement



142. A...1/4-20 B...5/16-18

494. Early '60's hood
 pad clip. black
 finish.

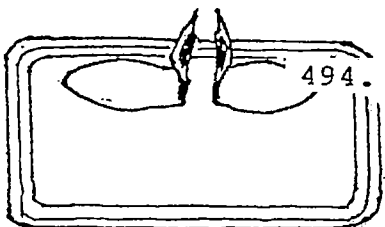

#459 Early '50s firewall
 grommet 2 equal size holes
 (also see #27,28,29

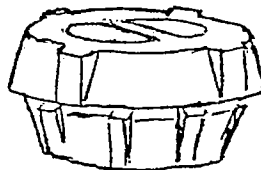

next page

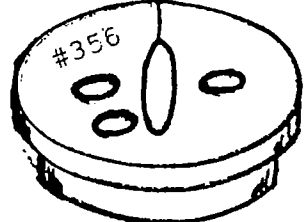
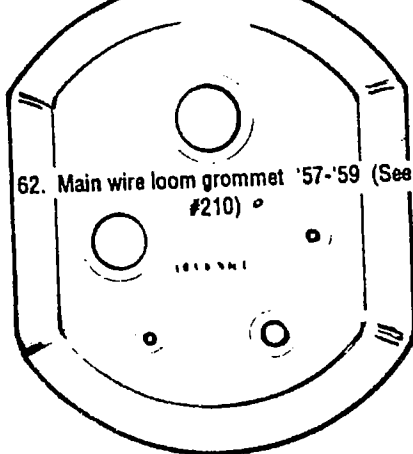
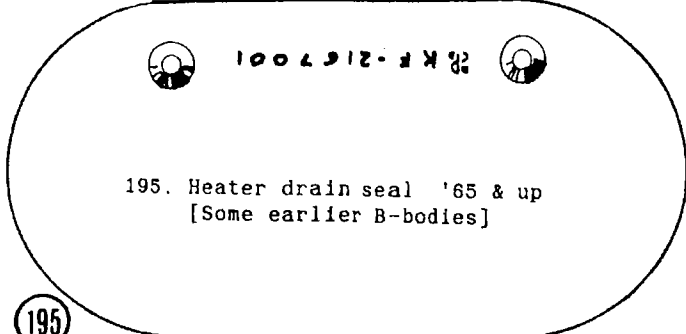

#356 '50-'54 Chrys. main wireloom gromm. on firewall

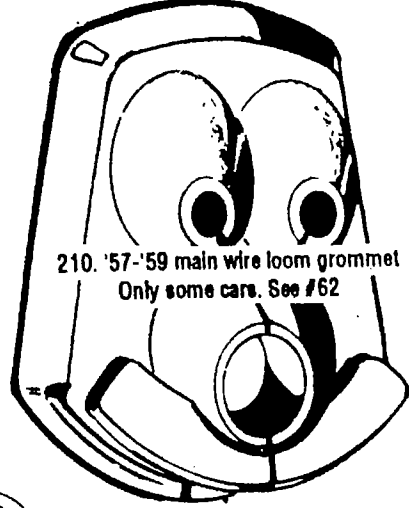
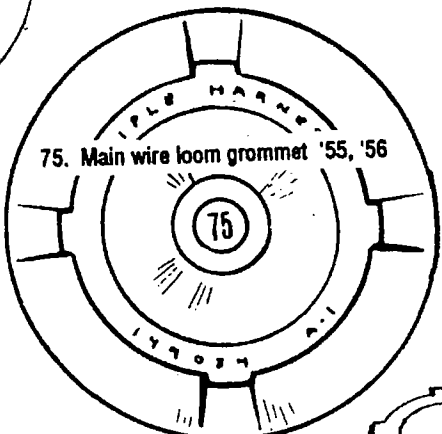
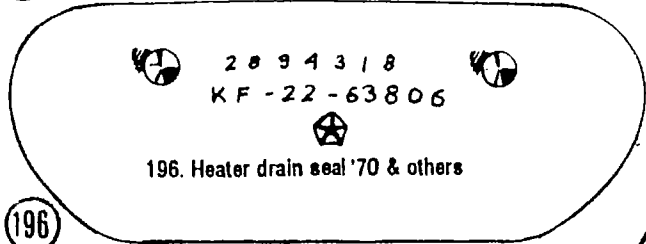

210. '57-'59 main wire loom grommet Only some cars. See #62

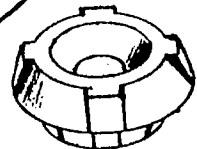
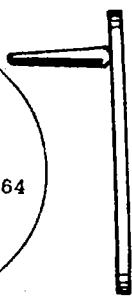
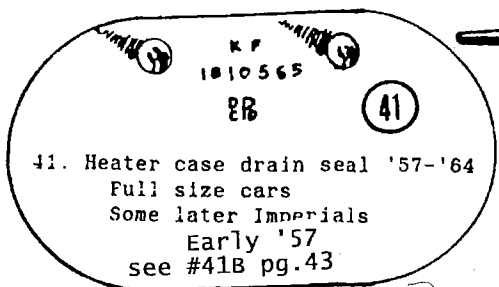

22. Fan shroud snubber '57-'65

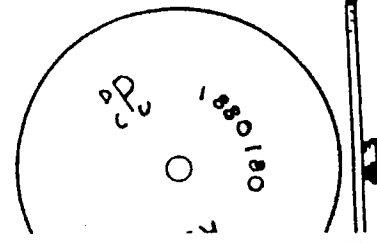

59. Inner drain seal on A/C units
'57-'65 most cars
'60-'62 top well drain seal



#475 '54 & earlier hood bumper

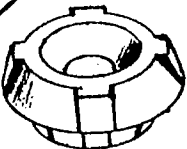

274. Parking light grommet on inner fender. '57, '58 Ply.

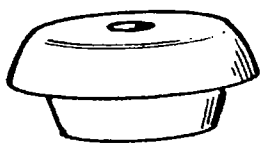

111. Speedo cable grommet '62



12. Air cleaner snubber '58, '59, '62 with dual air cleaners



191. Linkage bushing. '59-'64 see #14

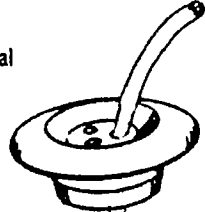

52. Tube & grommet (vacuum line) '59 & up

27 - 29. Firewall grommets '55-'59

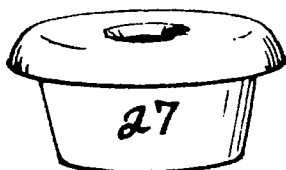

21. Trans cable grommet '56-'59

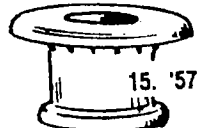
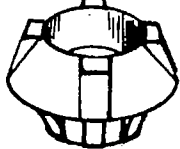

15. '57-'58 accelerator & trans linkage grommet



14. Accelerator & trans linkage grommet '59-'64

#478 Wireloom retainer '60s vehicles- white plastic clip to wireloom & snapped into hole.

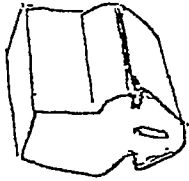

#545 Front side hood/fender bumpers '66 Ply. C-body. (See #239 Pg 23) for rear side bumpers.

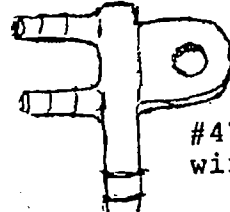

#471 '63-'70-A body windshield washer "T"

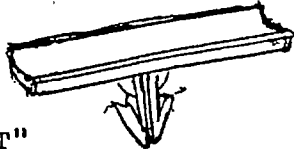

#452 White plastic bushing for fuel linkage rod '60-'6 C-Body

416
Wire loom straps, hard rubber, looks/works as orig, act size drawings

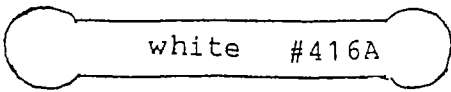

white #416A

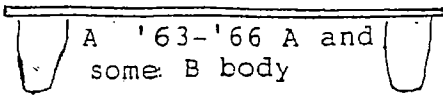

A '63-'66 A and some B body

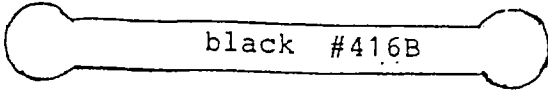

black #416B

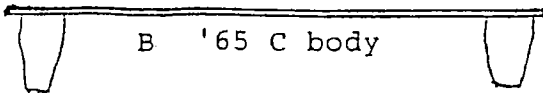

B '65 C body

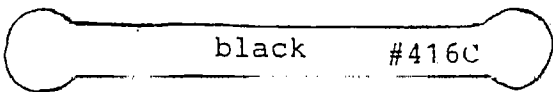

black #416C

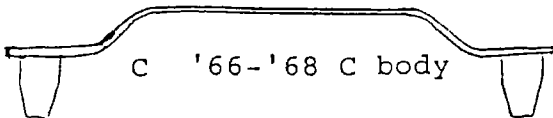

C '66-'68 C body

#363 '57-'59 A/C cars grommet for A/C lines through radiator core support.



#363

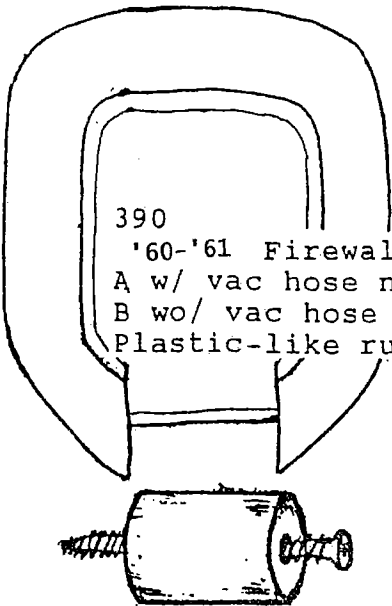

390
'60-'61 Firewall plug
A w/ vac hose nipple
B wo/ vac hose nipple
Plastic-like rubber

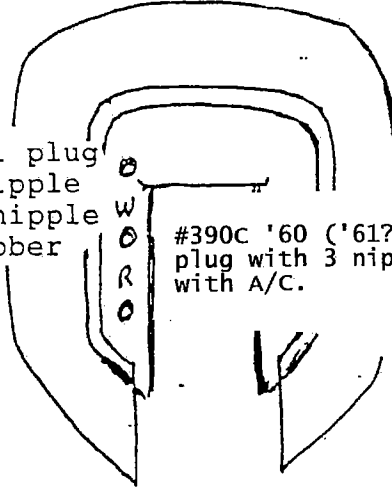

#390C '60 ('61?) Firewall plug with 3 nipples for cars with A/C.

#460 '57-'59 All Bumper & screw for rear corners of hood mounts on cowl. Dealer fix for rear of hood dropping below fender line. Set of 2

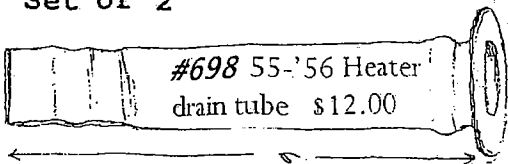

#698 55-'56 Heater drain tube \$12.00

#342 '79-'80 wire retainer interior fender liner



#342



404A '63-'64 A & B-body firewall grommet for trans cables

404B '65-'66 Black plug for auto trans.

#402 '62-'64 All Dart, Val, Ply.-Dod exc. 880 steering shaft coupling seal

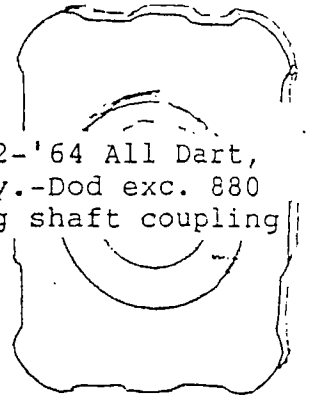

#244

A/C line grommet in rad. support. '58-'59 (see #363 this page)

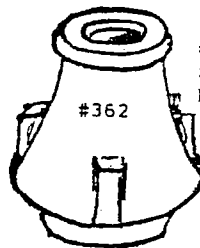
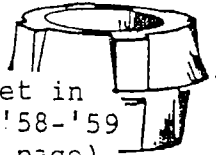

#362 '57-'58 A/C cars firewall grommet for power piston oil lines.

#362

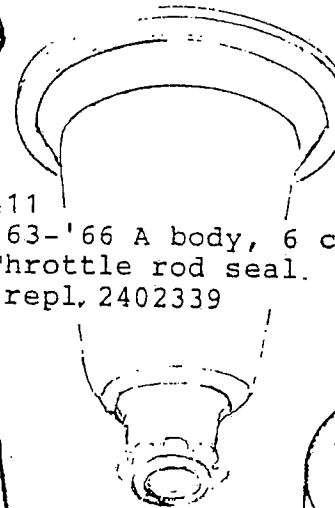

411
'63-'66 A body, 6 cyl Throttle rod seal. repl. 2402339

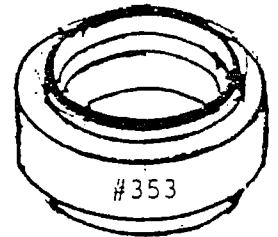

#353

Spark plug tube seal '51-'58 all Hemi engines

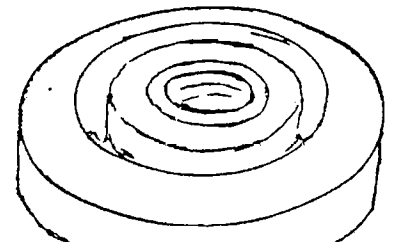

#410 '62-'66 A&B-body steering shaft seal, replaces 2266738 Bot. of column, white plastic center

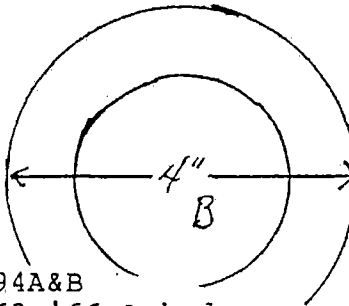

394A&B

'63-'66 A body

Blower motor plate--seals on firewall under hood
A--3/16" black sponge outer seal
B--5/8" black sponge inner seal

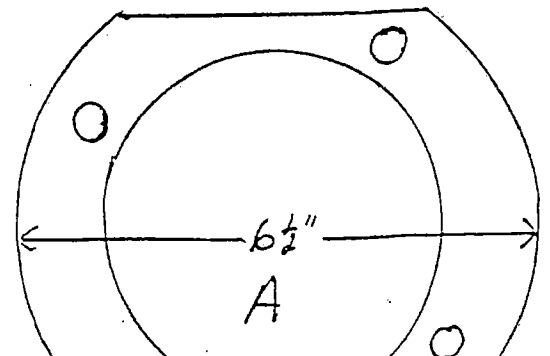

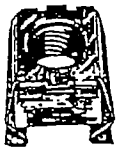

141. Cage Nut 5/8 - 18

407 '63-'66 A body
Cage nut--1/4-20 Inner
fender to metal splash
shield

A. 1/4-20x1 1/4" for heater case
B. 1/4-20x3/4" for misc.
fenderwell mounted parts



171.



413
Early V8s
RED plug
wire boot

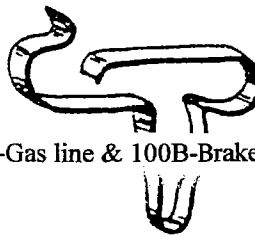

100A-Gas line & 100B-Brake line clips

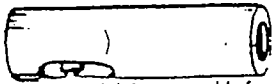

168. Ball joint assembly for fuel linkage. Male
& female thread - 1/4 - 28.



167. Wing nut A. 1/4-20
B 5/16-18 C. 3/8-16



164. Linkage clip for rams

181. Heater hose nipple. 5/8" hose,
3/8" male pipe thread, 1 1/2" long



169. Fenderwell bolt 5/16 - 18

170. Fenderwell bolt 1/4 - 20



293

Cast iron trans. Seal
between parking brake
backing plate and trans'
extension housing

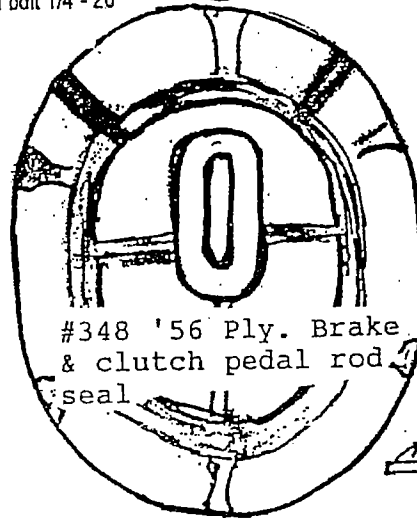

#348 '56 Ply. Brake
& clutch pedal rod
seal



Side view

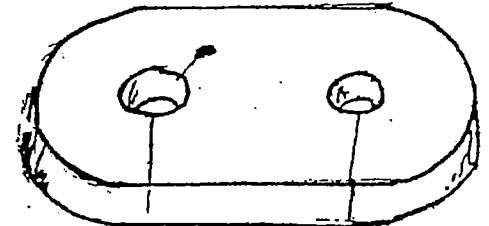

354 '59-'64 A/C line grommet
4 1/2"

320

'59&earlier? Gas
heater parts
A. Bumper
B. Lg grommet
C. Sm grommet
D. Tube

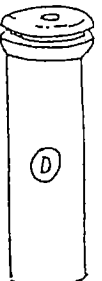
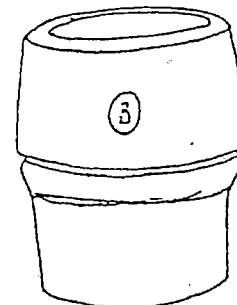

162. Engine to firewall ground wire.

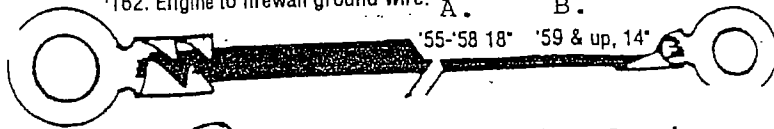

A. '55-'58 18" B. '59 & up, 14"

#163 white plastic vacuum lines
for ram cars (set of 2)

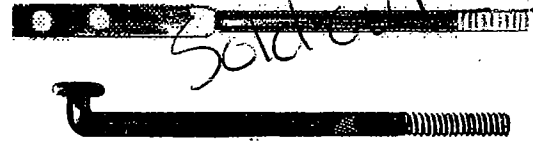
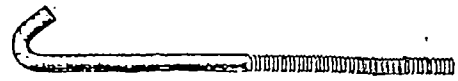

#189 Battery hold-down bolt
A. 3/8-16 x 10"
B. 1/4-20 x 9"
C. 5/16-18 x 8 5/8" flat end
D. 3/8-16 x 10 1/4" button end

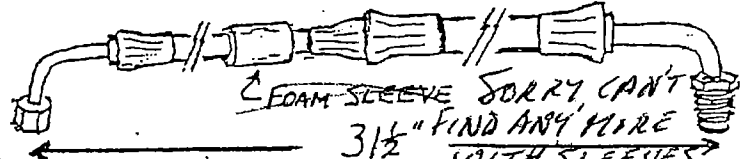

#479 Power steering pressure hose
'57-'66 most A,B,C bodies, Imperial

#480 5/8" power steering return hose
3ft. length/

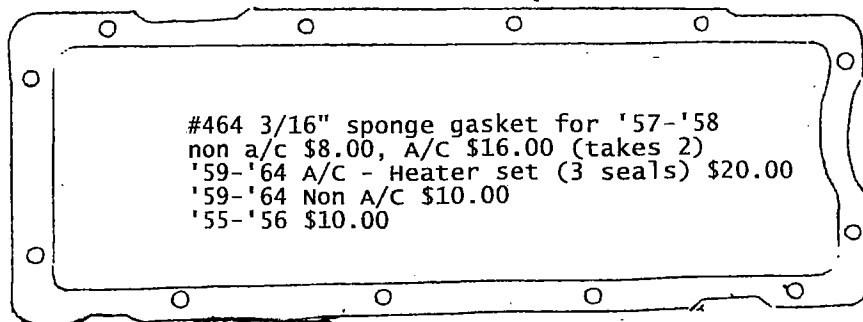

#464 3/16" sponge gasket for '57-'58
non a/c \$8.00, A/C \$16.00 (takes 2)
'59-'64 A/C - Heater set (3 seals) \$20.00
'59-'64 Non A/C \$10.00
'55-'56 \$10.00

Large blocks are 3/4" thick;
Small blocks are 5/16" thick.

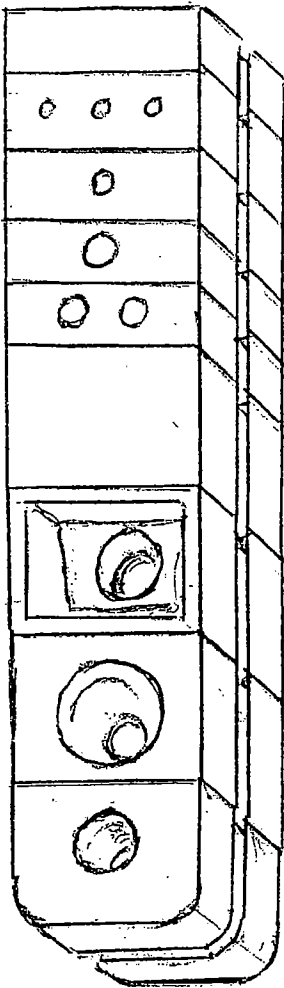

- A. Small blank \$2.50
- B. Remote mirror cables \$3.00
- C. Hood release cable \$3.00
- D. Vac. hose or speedo cable \$3.00
- E. A/C vac. motor hoses \$3.00
- F Large blank \$2.75
- G. Push button cable \$3.50
- H. Speedo cable \$3.50
- I. Main wire loom (bottom rounded block) \$3.50

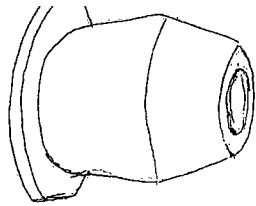

681 '56-'54 power brake master cyl. boot \$10

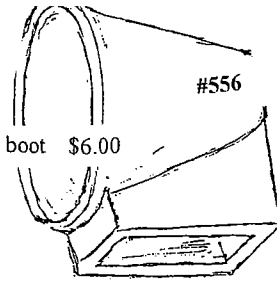

'60-'61 starter solenoid boot \$6.00

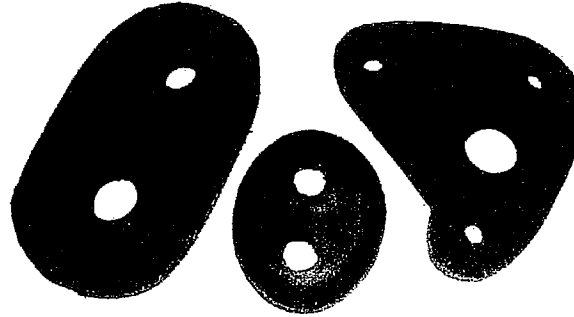

691 '65 and later heater-A/C sponge gasket and grommet set. \$14/set

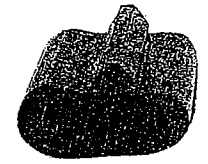

#620 hood to fender bumper \$1.80

#568 Oval air filters

- A. '57-'58 single carb; '57 dual carb \$12.00 each
- B. '58-'62 dual carb (except rams) \$22.00 each

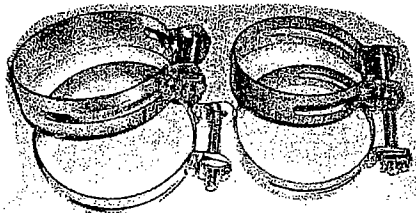
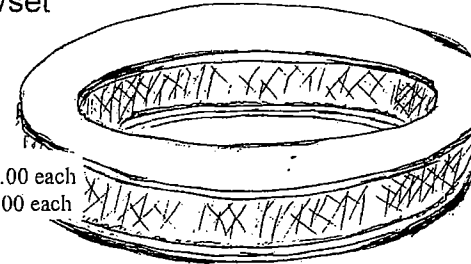

#558 '60-'64 ram intake equalizer tube hose clamps. Correct original style. Set of 4 (two sizes) \$10

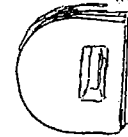

#557 '60-'61 starter hot lead insulator \$3.50

Start both tubes here -- install small one first; then big one over it.

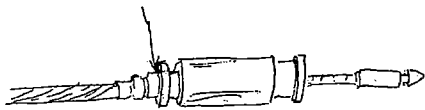

712 '57 A/C evaporator drain tube (plastic parts not included) \$10

Start big tube here over small tube catching about two threads of the adjuster portion.

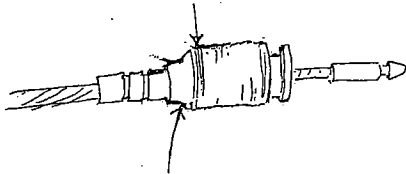

Start small tube here first.

#678

Shrink tube repair for trans shift cables. Trans cables rarely wear out except for the rubber or plastic covering which then causes a leak. A little time and cleaning will fix the problem. These special shrink tubes have glue built into the tube which is activated by the heat when shrinking. Two different sizes are used to get an original look and a perfect seal. Instructions included. \$23/set of two tubes

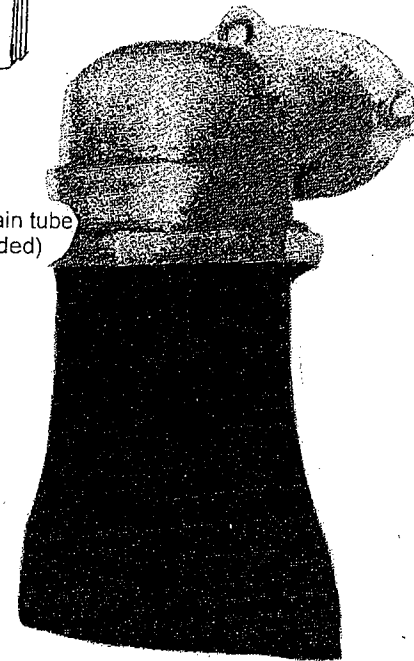

689

Molded fake tar top battery cover. This will fit '56-'59 group 27 replacement batteries with a flat top and both posts on the same side. The original or reproduction holddown frame used in these years hides the edges and holds it in place.

Sorry, for now you'll have to come up with the six screw in caps. The holes for the caps are not threaded; the caps push in tight enough to stay. The holes are open at the bottom so your battery is still vented.

\$20

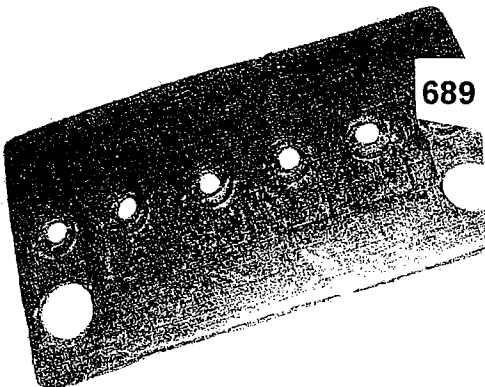

#510 '56-'60 starter, generator, distributor tags. Beautiful silkscreened aluminum tags complete your detailed restoration. Also available in red for 6 volt. Blank tags \$12.00 EACH

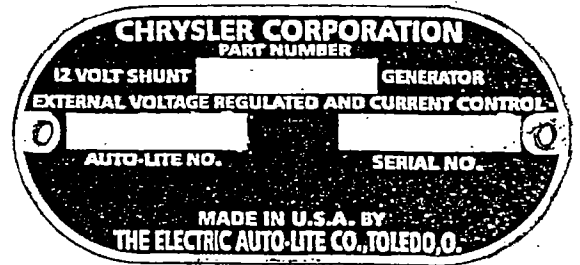
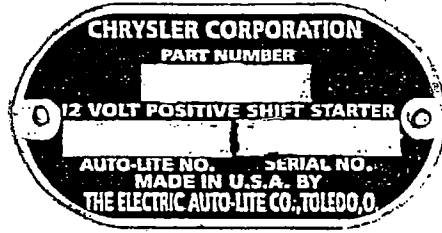
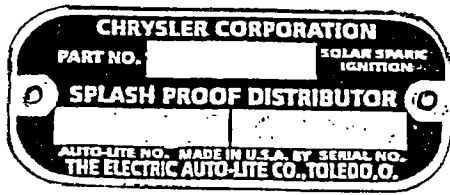

A. dist.

B. starter

C. gen.

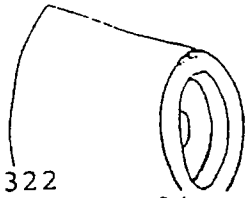

322 '59&earlier starter solenoid plunger boot

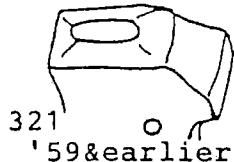

321 '59&earlier starter bendix drive lever boot

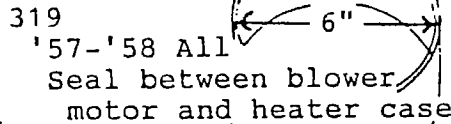

319 '57-'58 All Seal between blower motor and heater case

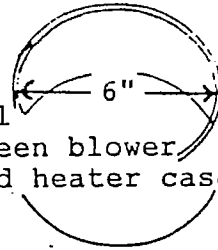

'63-'64 A-body Grommet in fire-wall for washer hose



251

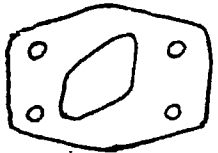

#331 Mid '50s-mid '60s master cylinder gasket die-cut heavy gasket paper

HOOD STOPS

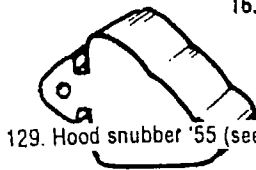

129. Hood snubber '55 (see #16);

16. Hood snubber '55-'60 (See #129)

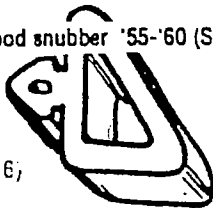

153. 56 Dodge Hood Snubber

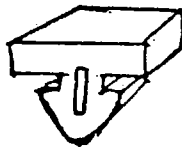

201. '59 Dodge hood snubber

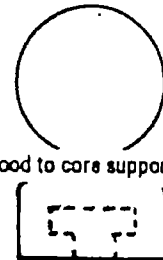

50. Hood to core support bumper '55-'61

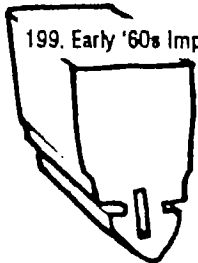

199. Early '60s Imp. hood snubber



208. '60-'61 Val. '61 Lan. hood snub

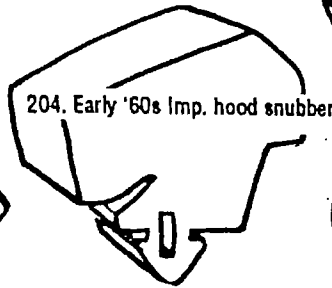

204. Early '60s Imp. hood snubber

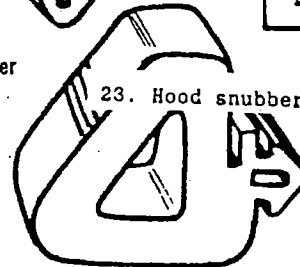

23. Hood snubber '61-'62 Chrysler [see #95]

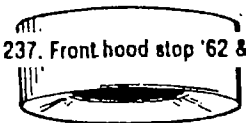

237. Front hood stop '62 & later

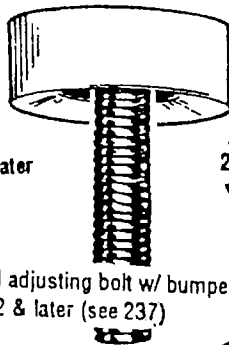

310. Hood adjusting bolt w/ bumper '62 & later (see 237)

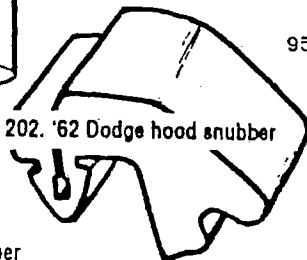

202. '62 Dodge hood snubber

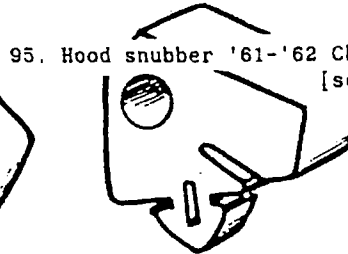

95. Hood snubber '61-'62 Chrysler [see #23]

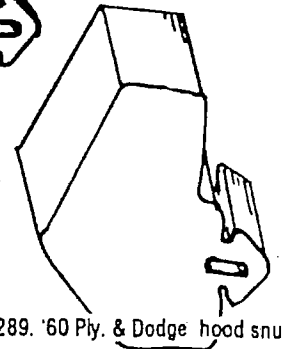

289. '60 Ply. & Dodge hood snubber.



#125 Hood bumper, rear corner '63-'70

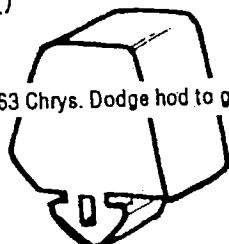

212. '63 Chrys. Dodge hod to grill

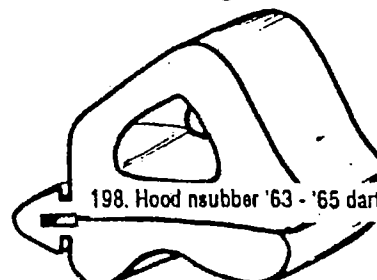

198. Hood nsubber '63 -'65 dart

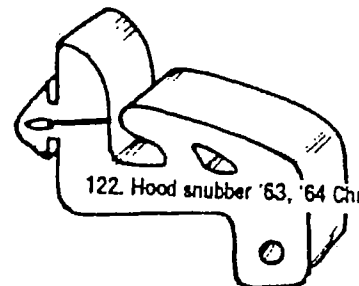

122. Hood snubber '63, '64 Chrysler

209. '63 Ply. Dodge hood snubber

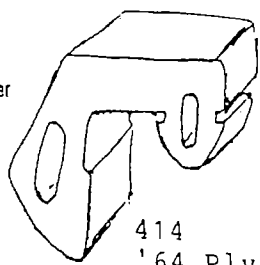
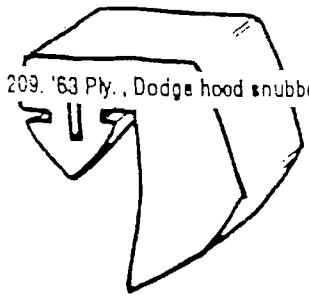

414
'64 Ply, Dod?
Hood snubber

238. Hood snubber '65, '66 Imp.

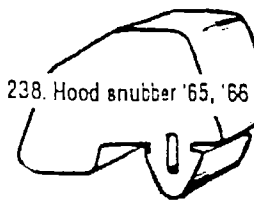

203. '65-'66 all hood snubber

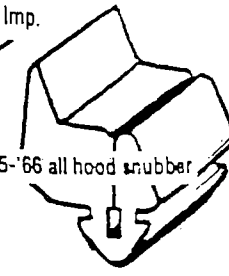

281. '65, '66 Dar, Val. Hood snubber

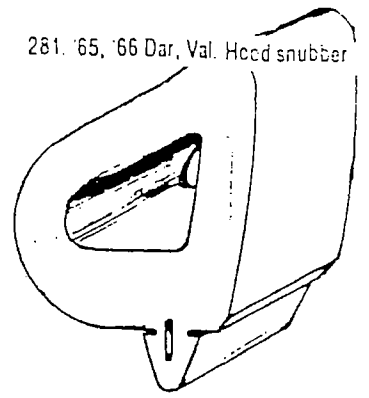

296. '66 Barracuda hood bumper

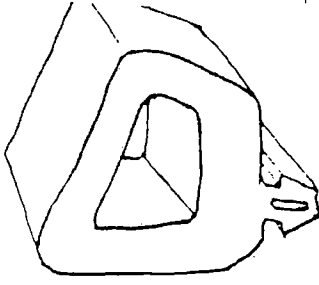

276 Hood snubber '67-'71 Dart, Valiant,
Duster

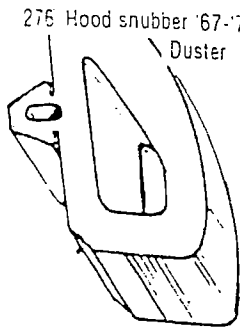

239. Hood snubber '67 up

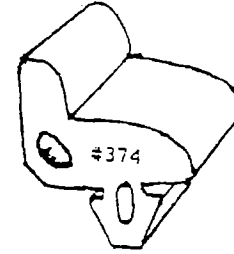
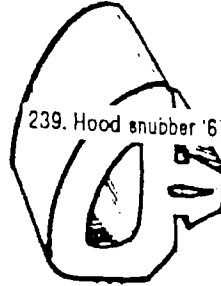

#374 '70-'74 Challenger
hood bumper.

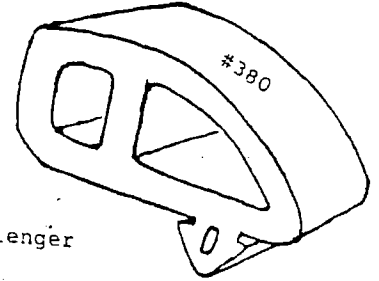

#380 '68 Imp. front
hood bumper

#372 '70-'74 Barracuda
hood bumper.

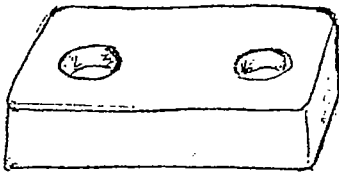
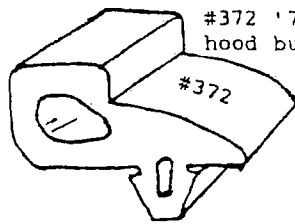

#538 '57 Dodge
Pick-up hood
Bumper

HORN RELAYS

R-1

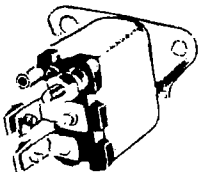

'56-'57 \$13.80

R-4



'63-'70 \$9.45

Horn relays for '58-'62 are very hard to find. R-1 will work; wire terminals have to be changed.

R-8 Starter relay will replace '56-'60 relay. Only the mounting strap is different.

STARTER RELAYS

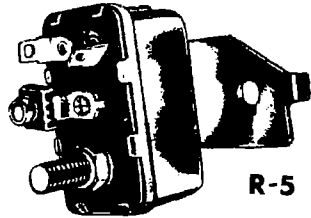

R-5

'67-'68 \$14.70

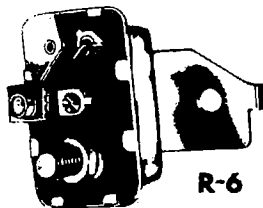

R-6

'67-'68 14.70

R-7

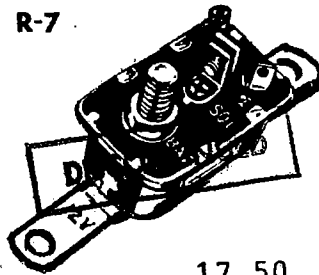

'56-'60 17.50

R-8

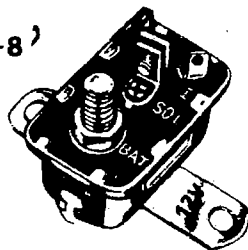

'61-'65 16.50

STARTER RELAYS

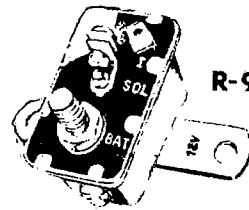

R-9

'61-'65 \$18.45

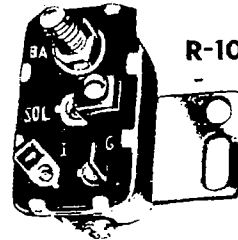

R-10

'65-'76 16.65

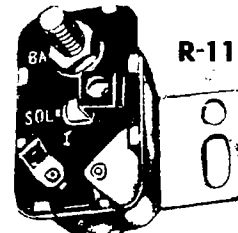

R-11

'65-'69 \$12.75

TEMP. SENDERS

T-2



'61-'68 1/8-27
thread \$11.25

T-3



'61-'82 1/8-27
thread \$11.25

OIL PRESSURE SENDERS

O-1



'53-'78 1/8 x 27
thread \$7.00

O-2



'62-'78 3/8x-18
thread \$7.60

O-3



'65-'82 \$27.60

O-4

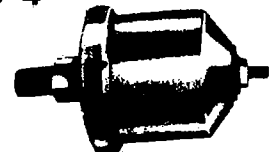

'60-'64 \$28.70

TEMP. SENDERS

T-1



'57-'60 1/4-18
thread \$11.25

STARTER SOLENOIDS

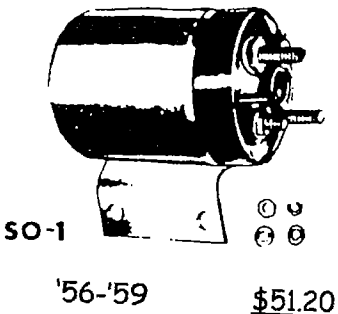

'56-'59 \$51.20

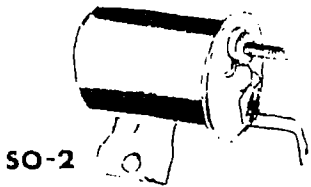

'60-'63 \$38.00

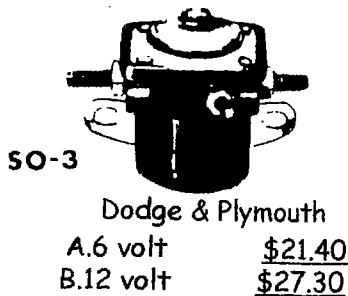

Dodge & Plymouth
A. 6 volt \$21.40
B. 12 volt \$27.30

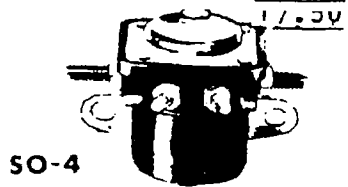

'60-'61 \$24.60

DISTRIBUTOR LEADS

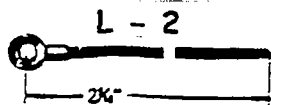

'51-'71 \$1.60

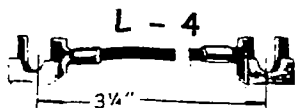

'51-'71 \$3.50

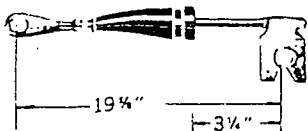

'61-'66 \$7.20

OIL LINES

#537 oil lines
A. '57-'59 oil pressure gauge line \$24.00
B. '57-'58 A/C set of 4 \$75.00 (some '57 cars may require adapting the return line to the engine)

STARTER & GENERATOR BRUSH SETS

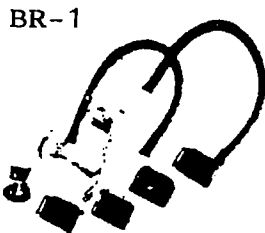

Chrys. #2275249
'61-'82 starter \$11.50

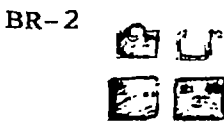

Chrys. #1843135
'53-'68 starter \$6.00

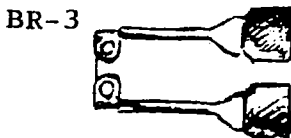

A. Chrys. #1253367
'51-'58 gen. \$6.25
B. Presto. #GCD, GCE
2012S '56-'60 gen. \$6.25

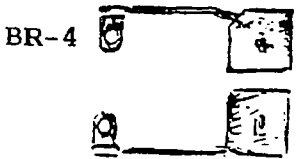

Presto. #GJC-201-
2AS '56-'61 gen. \$6.20

BRAKE LIGHT SWITCHES



'65-'82 \$5.10



'61-'66 \$6.20

B-1 '57-'60 all brake light switches. Can no longer find them with 1/4" pipe thread as original. Have found them with 1/8" pipe thread. I supply an adapter fitting with the switch. \$8.50 each
Note: These switches do not work long with silicon fluid. Best to leave pressure switch in place for looks and custom mount a B-2

NEUTRAL SWITCH



'57-'58 vacuum sw. on intake man. \$11.30

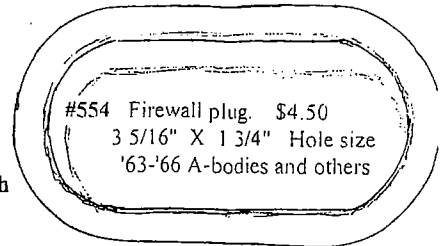

RADIATOR (CORE) SUPPORT & COWL SEALS

RADIATOR (CORE) SUPPORT TO HOOD

102	'55-'65 Chrys. see Pg. #25	\$12
W100	'56 Plymouth	\$16
W69	'63-'66 B-body	\$17
W81	'64-'65 A-body	\$19
W26B	'64-'65 Imperial	\$15
W70	'65 Fury, Polara	\$26
W82	'66 A-body	\$26
W69A	'66-'67 C-body	\$27
W68	'67-'69 A-body	\$24
W62A	'67-'71 B-body	\$23
W69C	'67-'68 Imperial	\$27
W69B	'68-'69 C-body	\$27
W61B	'70 A-body	\$24
W62B	'70-'71 C-body	\$23
W61A	'70-'74 E-body	\$24
W67	'72-'73 B-body	\$24
W92	'66 Imperial	\$26

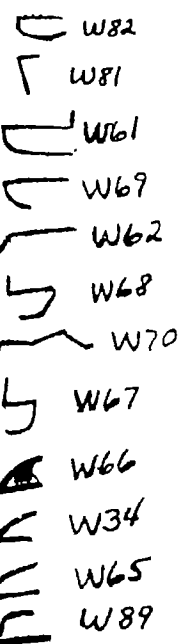

COWL-TO-HOOD

W71	'55 Chrys./Imp.	\$19
W71	'55-'56 DeSoto	\$19
W78	'56 Chrys./Imp.	\$18
W89	'56 Dodge/Ply.	\$18
W32	'57-'59 All exc Imp	\$18
W77	'57-'66 Imperial	\$23
W66A	'63-'66 A-body	\$18
W27	'60-'64 C-body	\$15
W66A	'62-'66 B-body	\$18
W66B	'65-'68 C-body	\$21
W64	'67-'75 A-body	\$19
W60	'67-'71 B-body	\$19
W66B	'67-'68 Imperial	\$21
W65	'69-'71 C-body	\$25
W34	'70-'74 E-body	\$21
W34	'72-'73 B-body	\$21

DRAWINGS NOT ACTUAL SIZE



Wire type clip for most hood-to-core-support seals

SPLASH SHIELDS

102-

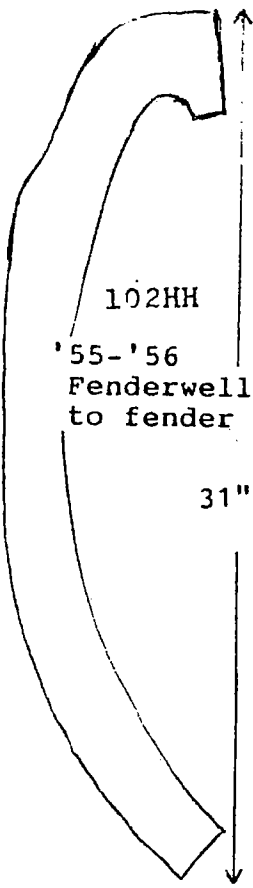

102HH
'55-'56
Fenderwell
to fender R&L

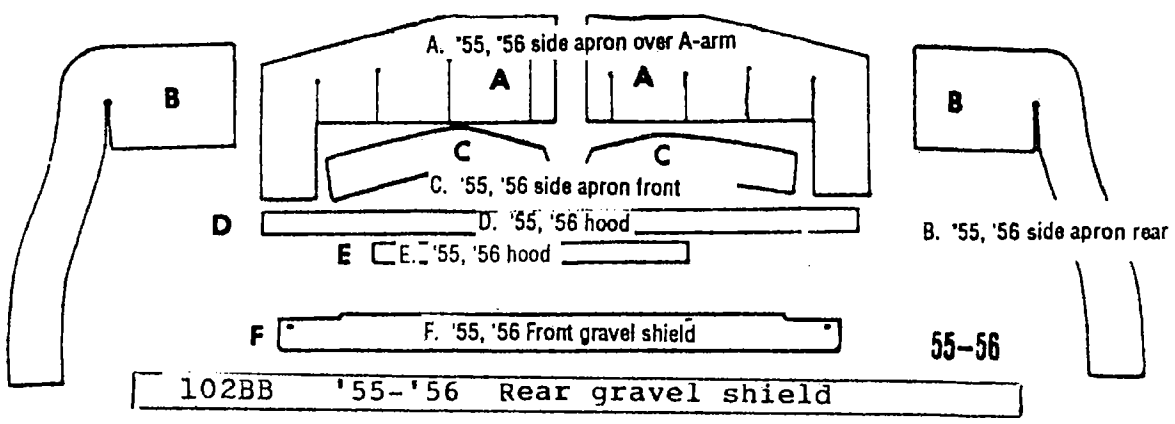

All splash shields are for Chrysler and DeSoto C-body unless labeled otherwise

W87 '57-'64 vertical seal between front fender and body. 2 ft long \$6.50

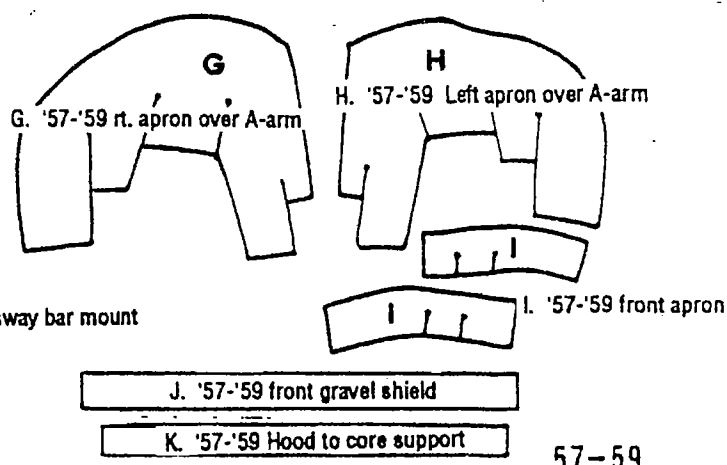

L. '57-'62 Rt. frame at sway bar mount

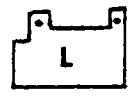

57-59

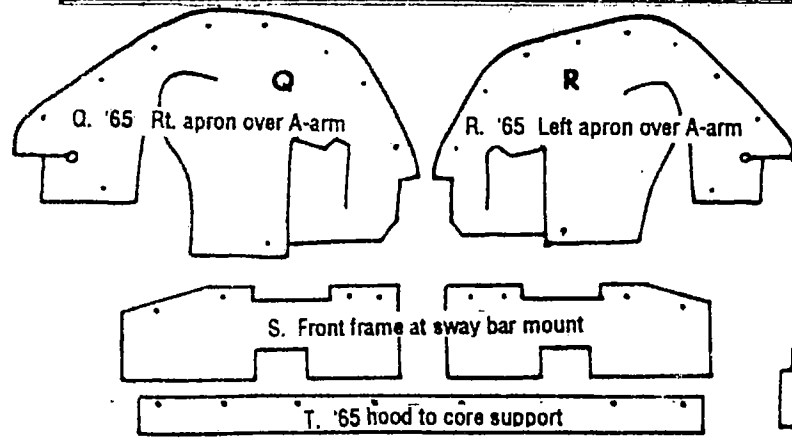

102AAA \$8.00

'60 CHRYS. SHORT WHEELBASE CARS, SOME LONG WHEELBASE CARS HOOD TO CORE SUPPORT - MOUNTS ON HOOD - USE 8 #12 CAPS SEE 102 YI FOR SEAL MOUNTED ON CORE SUPPORT

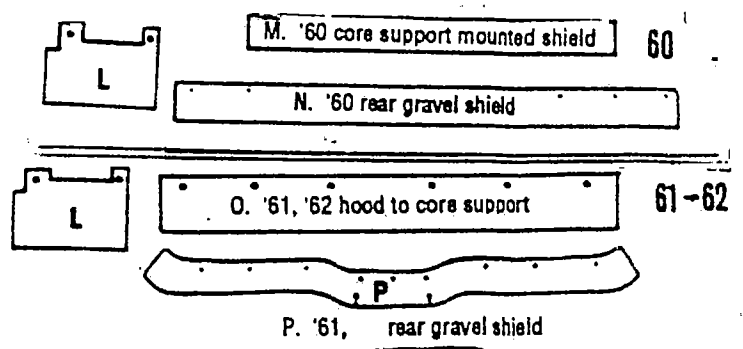

'66-'68 C-body almost the same as Q, R, S. Order Q, R, S and state year ('66-'68)

Most early cars used staples to fasten the splash shields. Heavy duty staples are included and must be installed one at a time by hand. Use an ice pick to punch holes.

Most '62 & newer splash shields take small wire type fasteners. These are not available, but were used for years on almost all cars. Check your wrecking yard.

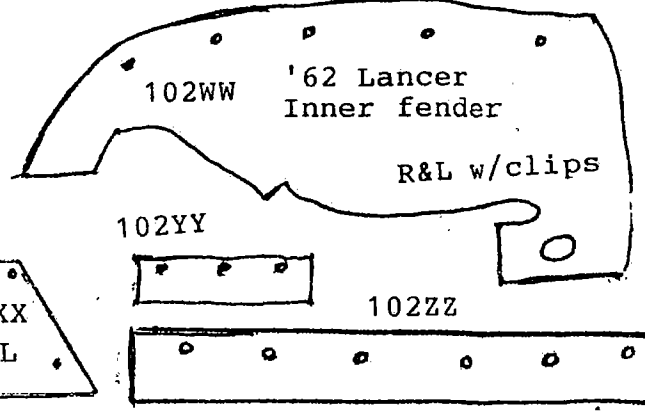

Front bumper '66 Dart

U. '63, '64 Rt. apron over A-arm

W. '63, '64 hood to core support

V. '63, '64 Lf. apron over A-arm

102II
'64-'66 Imperial, left

102KKA
'73 Imperial, left
right opposite

102KKB
'67-'68 Imperial

102JJ
'64-'66 Imperial, right

HOOD-TO-CORE-SUPPORT SEALS
ARE UNDER SEPARATE LISTING

63-64

102LL

102MM

Right

102NN

102Y

'57-'59 Plymouth
Dodge

'56 Dodge, Plymouth

102Z

'59 Plymouth rear
gravel shield

102PP

Left

102QQ

10200

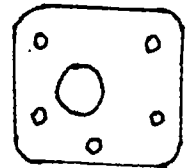

102RR '56 Dodge, Plymouth R&L opposites

102AA

'57-'59 Dodge and
Plymouth steering
column base plate
gasket

102X
'61-'63 Imperial hood

102CC

'59 Imperial rear of
inner fenderwell R&L

102EE

R&L

'70 Chrysler

102GG

R&L

102DDA

'59-'63 Imperial over
A-arm R&L

102FF R&L

(Probably fits '69-'71
Chrysler and Imperial)

102DDB '60-'62

short wheel base cars

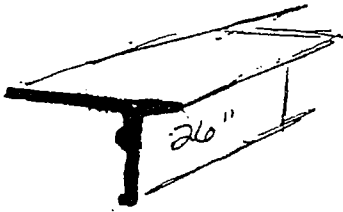

"T" rubber seal
between inner splash
panel & front fender.
Most A & B bodies. Use
#430 plastic clips. 26"
length. \$12.00

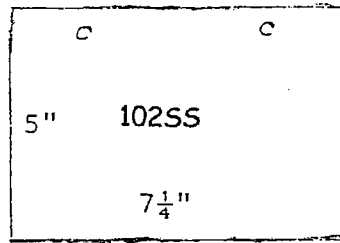

'63-'65 A-body

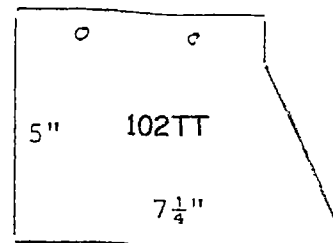

'66 A-body

Splash shield on outer front
frame rail at bumper bracket
mounting point

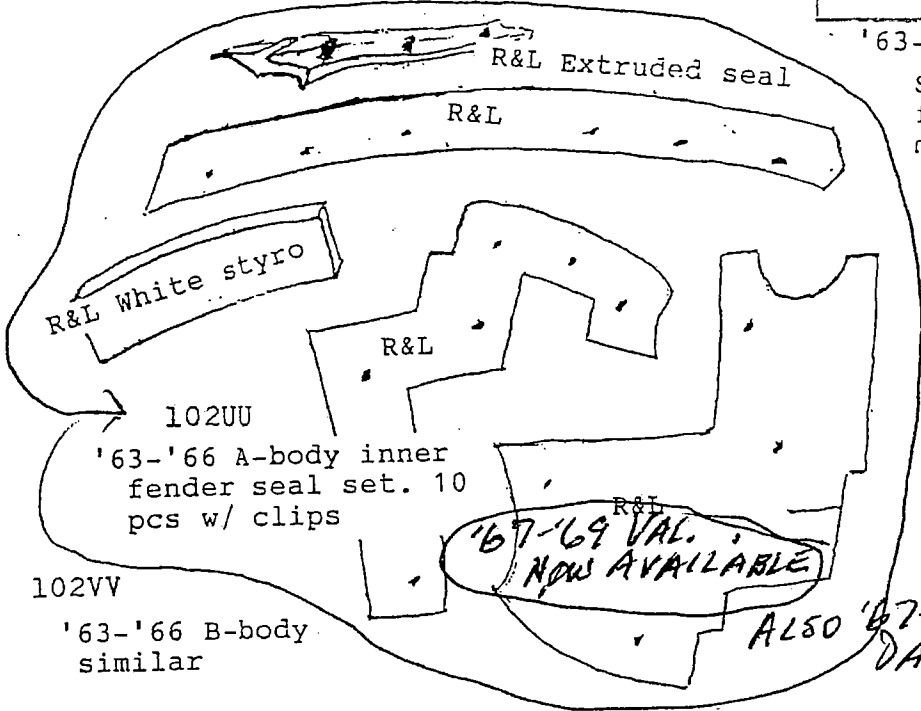

R&L White styro

102UU

'63-'66 A-body inner
fender seal set. 10
pcs w/ clips

102VV

'63-'66 B-body
similar

'67-'69 VAL.
NOW AVAILABLE

ALSO '67-'69
DART

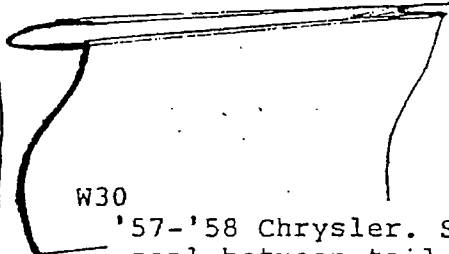

W30

'57-'58 Chrysler. Special
seal between tail light
filler and bumper \$8.90p.

DRAWINGS NOT

ACTUAL SIZE

BODY — PLUGS & MISC.

FRONT AND REAR BUMPER SHIELDS

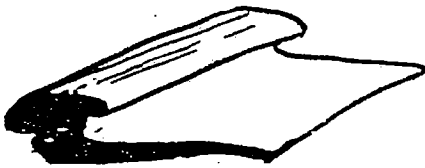

W112 '60 Plymouth shield
under rear bumper \$36.00

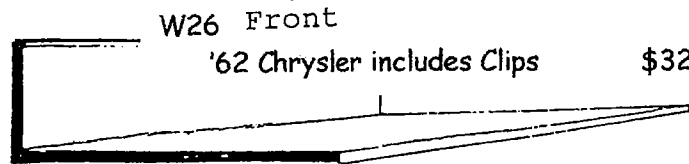

W26 Front

'62 Chrysler includes Clips \$32.00

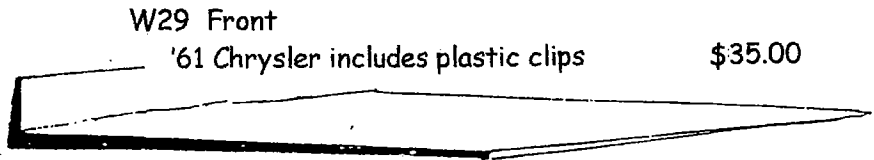

W29 Front

'61 Chrysler includes plastic clips \$35.00

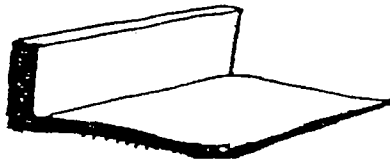

W113 '63-'65 Belvedere, Sat.
shield under rear bumper
\$32.00

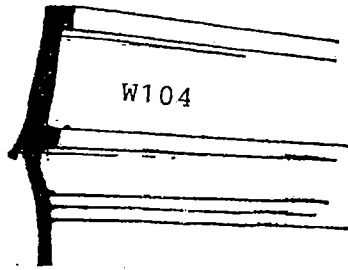

W104

shield under rear bumper
'66-'67 Charger & others
75" strip \$36.00

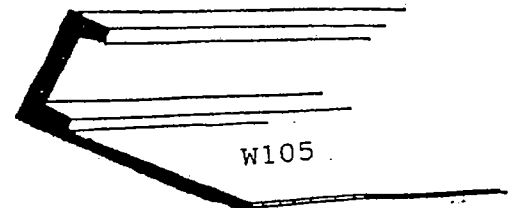

W105

Shield under rear bumper
'70 B-body
'65 Chrysler
74" strip
\$32.00

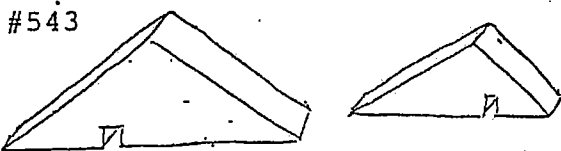

#543

'63-'66 A-body - replacements
for dense styro fillers where
front framework meets the fire
wall. Molded with dense white
urethane foam. does not retain
water.

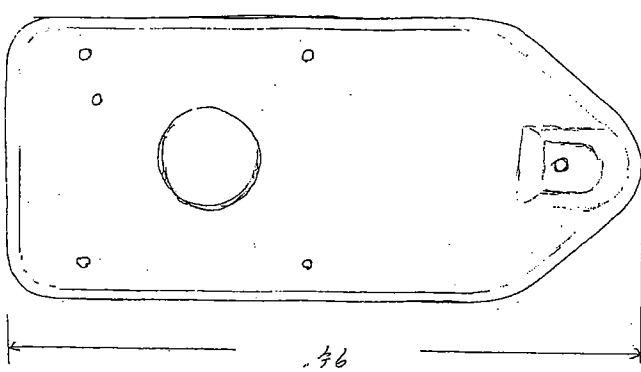

#609 '63-'66 A-body fuel filler tube to trunk floor seal. Need old one for metal core. \$30.00

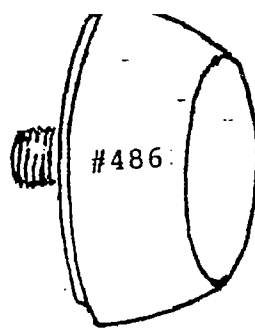

#486
'59 Desoto fr. bumper cushion

#476 '57-'59 Sta. Wag. rear bumper step pad

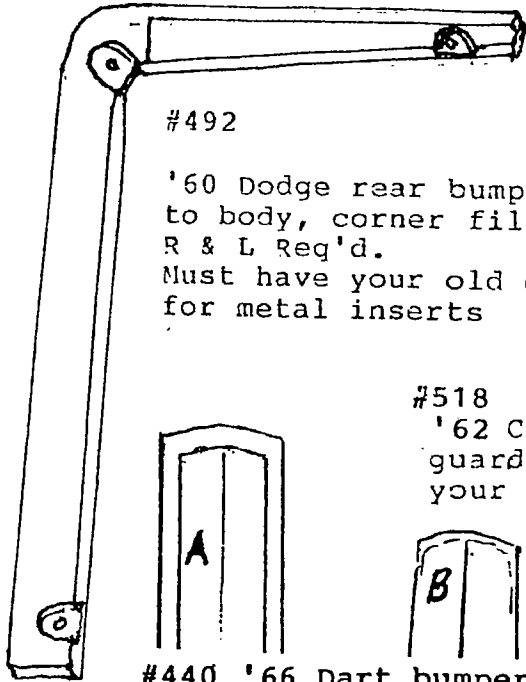
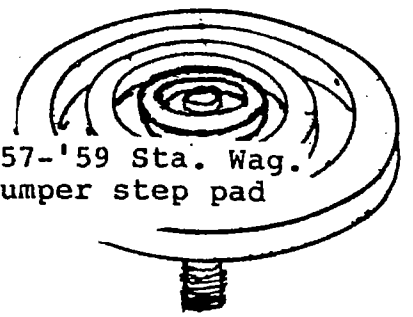

#492

'60 Dodge rear bumper to body, corner fillers R & L Req'd. Must have your old ones for metal inserts

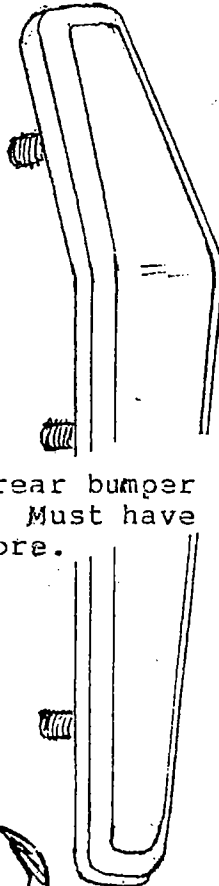

#518

'62 Chrys rear bumper guard pad. Must have your old core.

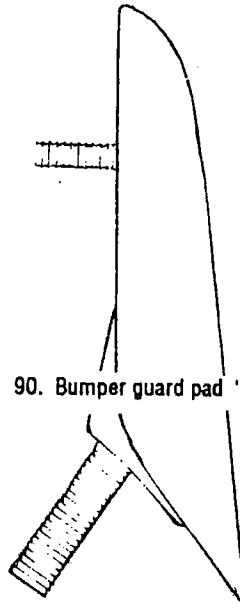

90. Bumper guard pad '60, '61 Exch.

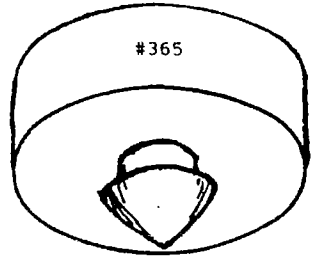

#365

#365 '57-'59 trunk floor to frame bumper.

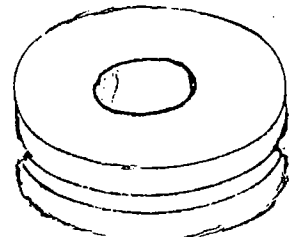

187. Rear transmount '62 Chrysler

40. Rear spring clamp insulator '55-'65

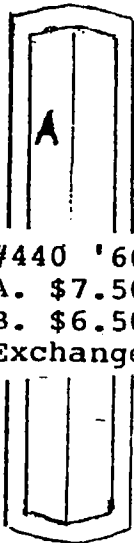
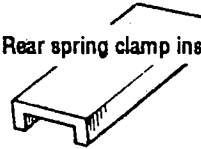

#440 '66 Dart bumper pads
A. \$7.50
B. \$6.50
Exchange

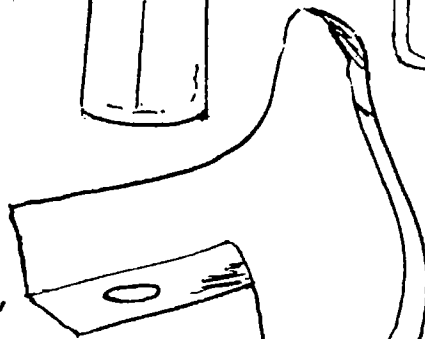
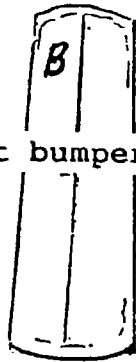

287. '65 Val. rear bumper snubber (bolts to quarter panel)

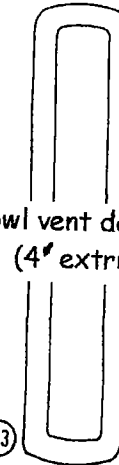

113. cowl vent door seal '55-'56 (4' extruded strip)

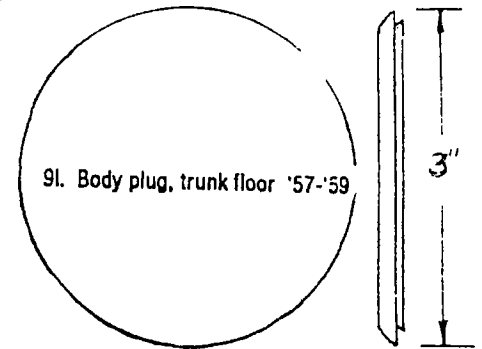

91. Body plug, trunk floor '57-'59

190 Sheet metal plug, black plastic

- A. 1/2"
- B. 3/4"
- C. 7/8"
- D. flush 1"
- D. recess 1"
- E. 1-1/4"
- F. 1-1/2"
- G. 1-3/4"
- H. 1-7/8"
- I. 2"
- J. 2-1/2"

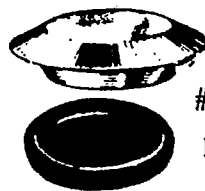

A-D
#190
D-J

156. Rubber Body Plug
A. 2 1/4" hole
B. 1 7/8" hole

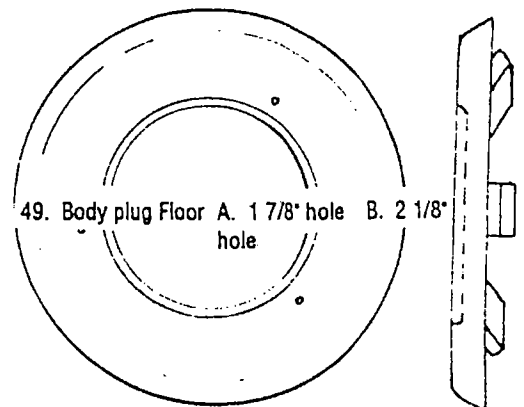

49. Body plug Floor A. 1 7/8" hole B. 2 1/8" hole

#339A Molded body mounts

'55 & later

#339B Tall center

(fits into 339A)

#339C Short center

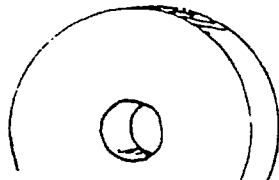

#294 Rubber body mount pads. A. 1/2" thick
B. 1/8" thick to shim A if necessary

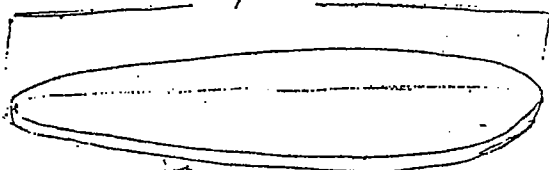
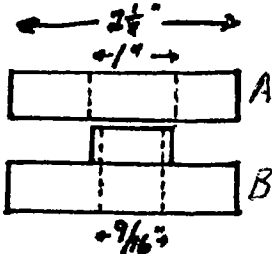

#544 '62 Dodge fr & rear bumper guard pads exchange

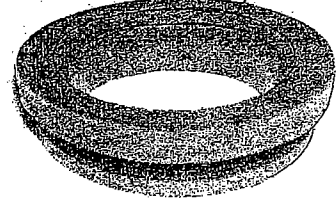

#613 '65-'66 A-body fuel filler tube to tank grommet. \$8.60

341 R&L pads between rear bumper & body '62 Chrys. (exchange only)

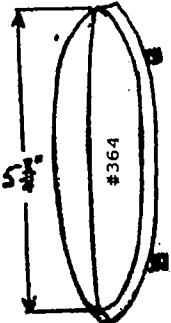
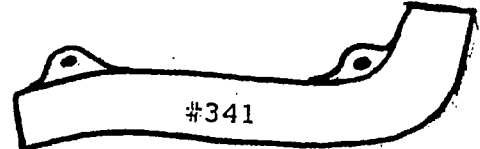

#364 '65 Plymouth rear bumper guard pad. (EXCHANGE)



#140D 1/2"-13 X 1 3/8" bumper bolt--pan head Not as rounded as 140A

#140 Stainless steel capped bumper bolt
A. 1/2"-13x1-1/4"
B. 7/16"-14x1-1/4"
C. 3/8"-16x1"

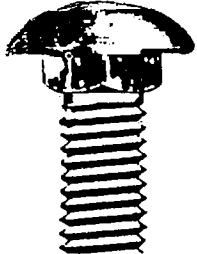

279. Special snap-in stud for rear bumper '57-'58 Chrysler

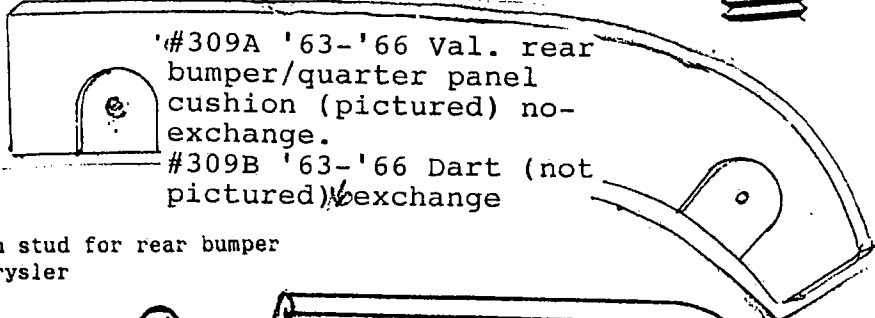

#309A '63-'66 Val. rear bumper/quarter panel cushion (pictured) no-exchange.
#309B '63-'66 Dart (not pictured) exchange

200. '60-'62 rear bumper snubber

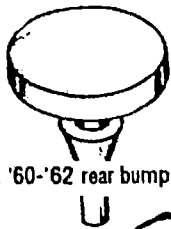

5. Gas door snubber '57-'59 C. Des

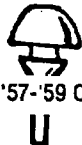

4. Gas door snubber '59 Dodge

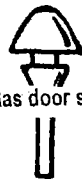

#444 '55-'56 Dodge gas door bumper

13. Gas door snubber '59 Plymouth



275. Gas door snubber '62 Chry.



#443 '57-'63 Imp. gas door snubber



20. Gas door snubber '60-'61



#491

'63-'65 A-body rear license plate mounting clip



33. License plate snubber '57-'65 front



71. Gas door bumper '55

Chrys./Des.

70. Gas door bumper '56

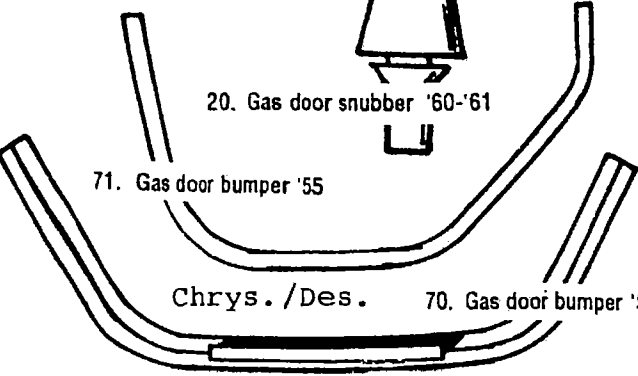

#470 '63-'65 A-Body rear lic. plate snubber



10. License plate snubber '60 and up



382 License plate nut Nylon- use with #383



383 License plate screw Use w/382 nut



9. License plate snubber '57-'58 rear



SOCKET & PIGTAIL ASSEMBLIES

P-1 \$2.10



Pigtail complete with terminal. Lamp #53, 55, 57, 1895

P-2 \$2.80

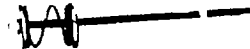

Pigtail complete with terminal. Lamp #67, 89, 93, 97, 1003, 1073, 1141, 1156

P-3 \$3.20

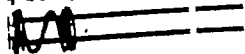

Pigtail with terminals for double contact base sockets. Lamp #1034, 1154, 1157, 1158, 1176, 1178

P-4 \$5.10

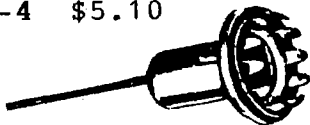

Single contact socket Lamp #67, 89, 93, 97, 1003, 1073, 1141, 1156

P-5 \$4.60

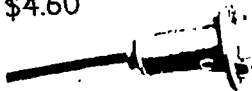

Single contact socket Lamp #53, 55, 57, 1895

P-6 \$4.80

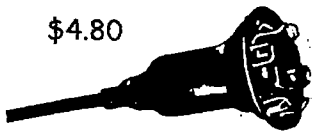

Single contact socket, rubber covered. Lamp #53, 55, 57, 1895

P-7 \$5.70

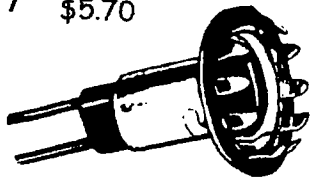

Double contact socket. Lamp # 1034, 1154, 1157



#386 Nut headlamp door mtg plastic

#504 Free spinning washer nuts.

- A. 1/4"-20
- B. 5/16"-18
- C. 3/8"-16
- D. 10-24

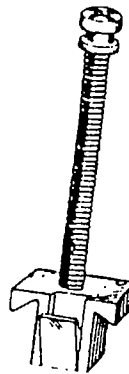

398 '67-'70 Headlamp adj screw



145. 10-24 nut



401 repl 152867 see 400 Headlamp door spacer

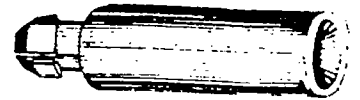

400 '68-'69 repl 6027014 Headlamp door spacer



185. Thread cutting nuts for stud sizes A. 1/4" B. 1/8" C. 3/16" D. 5/32"



180. Tubular speed nut for stud sizes A. 1/8" B. 3/32"

137. Hood letter clips '57-'59 Chrys. 300



682 2 wire hole grommet early 70's for 7/8" hole \$5.80



#139 Wheel cover snubber for '56 Plymouth



#178 Push on speed nut A. 3/32" B. 1/8" C. 1/16" D. 5/32"

FIBRE WIRE LOOM



307. Wire cover, A. 1/4" I.D. B. 3/8" I.D., C. 1/2" I.D.



#345 Fuel tank support stud. 3/8"-16x4 1/2 '57-'62



#388 8-18x3/8" Phillips head (washer) screw--br zinc. Wheel opening mold etc.

UNIVERSAL MOULDING CLIPS

SEE NEXT PAGE

CLIP INSTALLATION NOTES

Curved edges of these universal clips allow installation in a wide range of stainless mouldings.

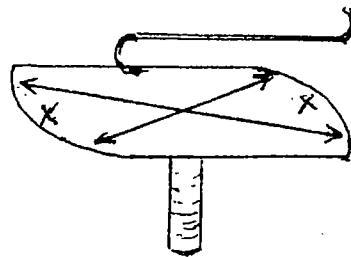

All clip illustrations are actual size. Simply measure between points shown by arrows to find size range. "X"

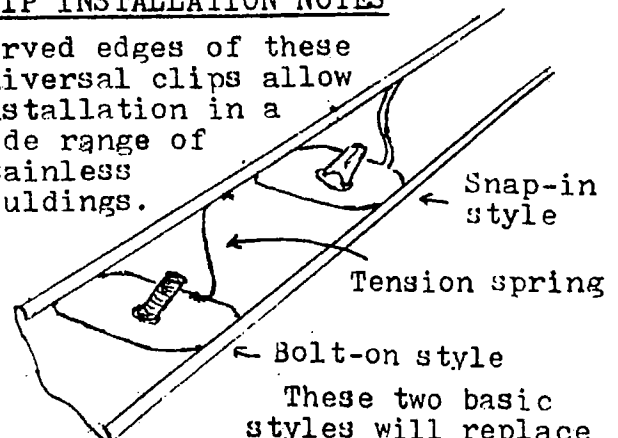

These two basic styles will replace most original flat metal clips mounted on the body.

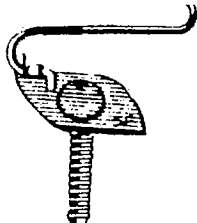

A12744
10-24X3/4

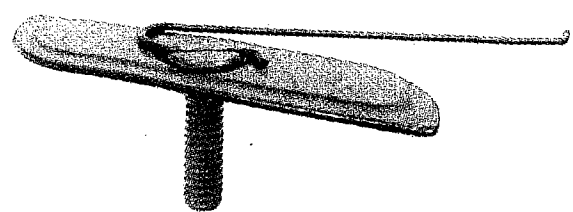

19807

\$2.00

Moulding Fastener
#10-24 x 3/4" Bolt
Plate Length: 2-17/32"
Plate Width: 11/16"

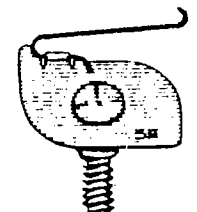

A12514
10-24X1/2

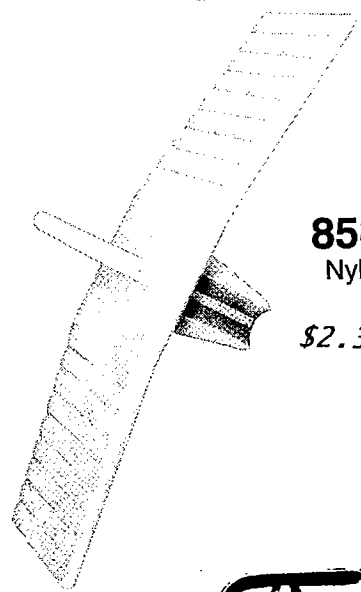

8581
Nylon

\$2.30

Moulding Fastener
Plate Length: 3"
Plate Width: 3/4"
Break Off Plate
At 5/32" Perforations
To Fit Moulding

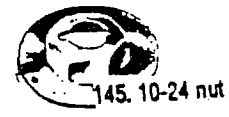

145. 10-24 nut

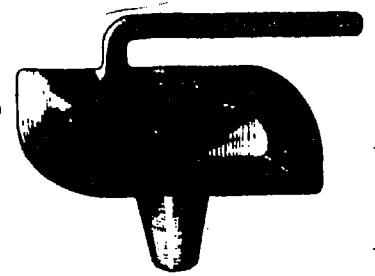

8400

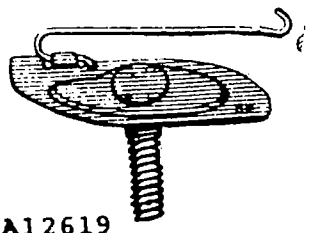

A12619
10-24X3/4

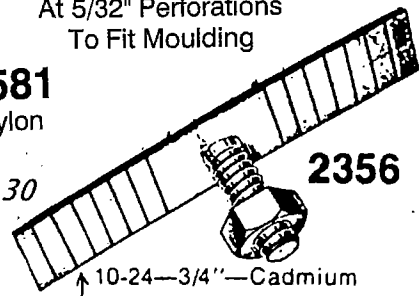

2356

10-24-3/4"—Cadmium

Break off for
correct size

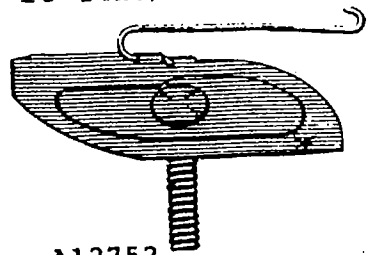

A12752
10-24X1/2

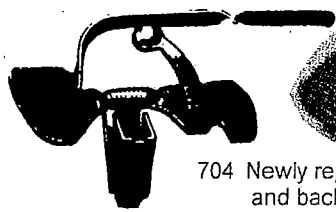

A12618

704 Newly reproduced upper windshield
and back glass upper trim clip '60 and later
B and C bodies. \$2.00 each

Plastic snap-
in style

8386

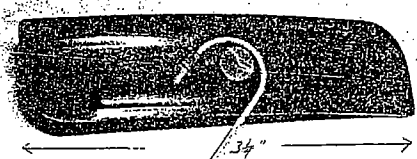

#615 moulding clip with
10-24 stud. \$2.30

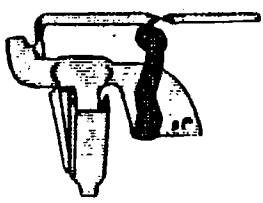

A12943

10794

Screw Size 10-24
Length 3/4"
PLATE Length 4-1/2"
W/SEALER



8399

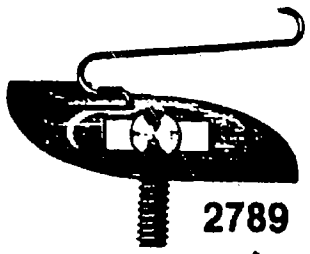

2789

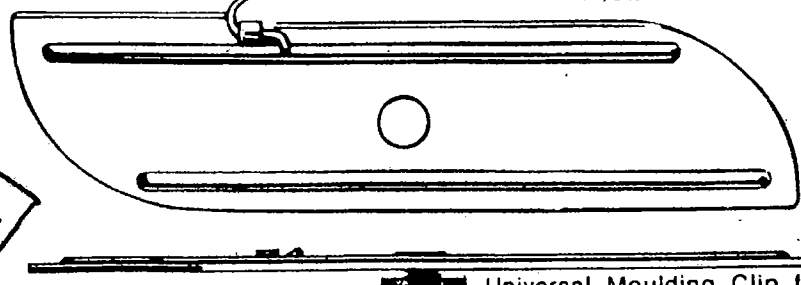

Universal Moulding Clip for
4" Moulding:

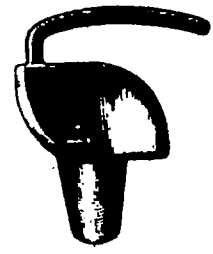

8398

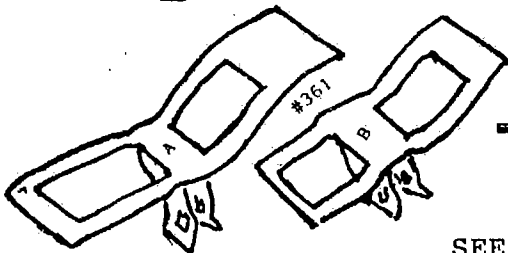

'60-'62 Lower windshield &
backglass trim clips. good
used

SEE INSTALLATION NOTES
ON PRECEDING PAGE

'57-'59 LOWER
WINDSHIELD MOULDING
CLIPS (SEE PG. 40)

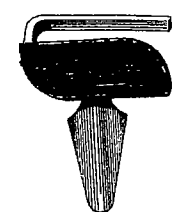

8843

MOLDING CLIPS & FASTENERS

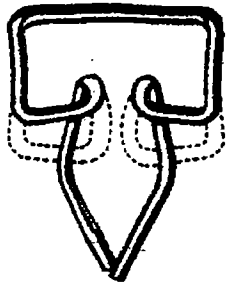

#639 '58-'59 Chrysler, front fender & rear quarter panel molding clip. \$1.00 ea.

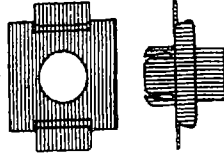

#627 Mopar 6001428 \$1.10 ea.

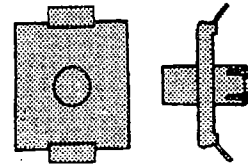

#628 Mopar 6001943 \$1.10 ea.

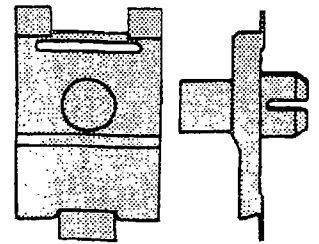

#629 Mopar 6001482 \$1.10 ea.

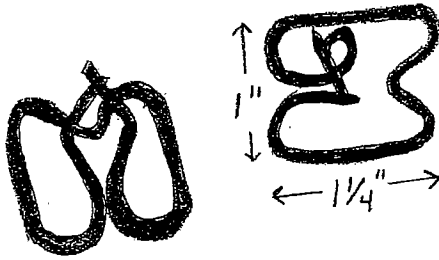

#618 molding clip \$1.50

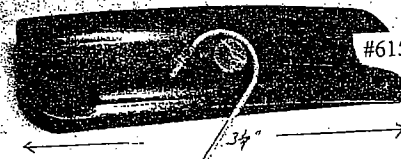

#615 molding clip with 10-24 stud. \$2.30

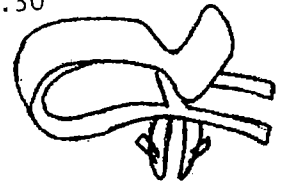

#616 wire clip - front valance '60-up \$2.60



#617 wiper arm pivot clip center \$1.60

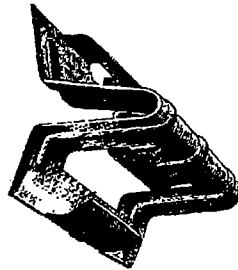

#619 '60 Plymouth clip for molding on top of fins. \$2.50

710 wire clip for '57-'59 cowl vent screen - fits in turned 90 from original, but works! \$1.50 each

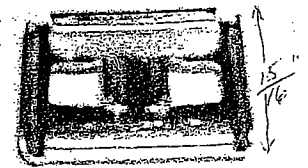

#621 '57 Plymouth molding clip \$1.75



#638 '57 Plymouth, front fender lower molding clip. \$1.00 ea.

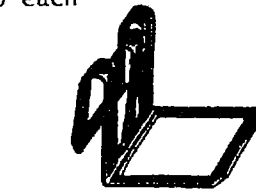

#623 door & window crank handle clip '55-'56, '57 & up - some \$2.00

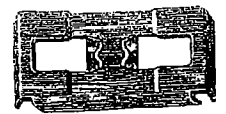

#635 '57-'58 Plymouth quarter panel clip \$1.40 ea.

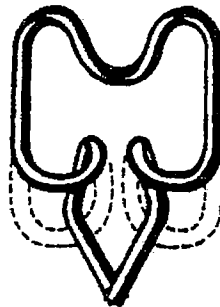

#640 All '59 Dodge, Plymouth (except Custom Royal) body sidesweep upper or lower wide molding clip. \$1.00 ea.



#637 '57 Plymouth, front fender upper molding clip. \$1.00 ea.



#633 '63 Dodge & Plymouth .212" wide \$1.60 ea.

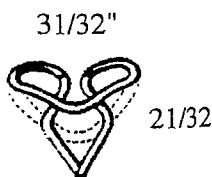

#641 '60 Plymouth quarter panel molding fastener. \$1.00 ea.



#622 clip for heater cable \$1.60



#642 '60 Dodge body side molding fastener. \$1.00 ea.



#643 Fastens aluminum trim to front seat side sheet metal. \$.90 ea.

WOW! CHECK THESE OUT! BEAUTIFUL RECREATIONS OF IMPOSSIBLE TO FIND SPECIALTY FASTENERS. Plated to resist corrosion. Some are ready now; the rest should be ready soon!!

THEY ARE FINALLY HERE!

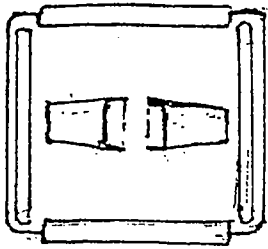

#495 '57-'59 300 side moulding clip.
'57 Desoto

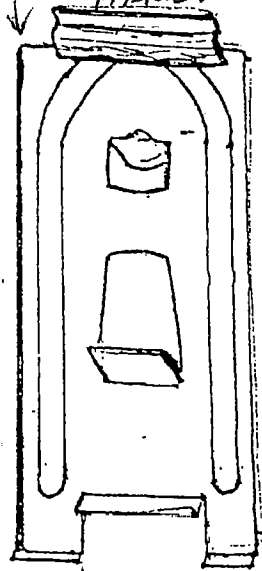

#497 '59 rocker moulding clip.

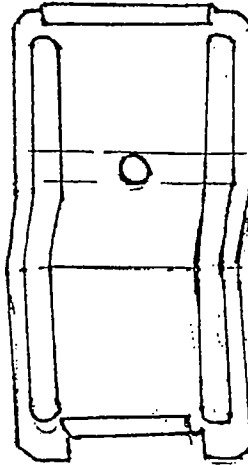

#498 '60-'64 rocker moulding clip.

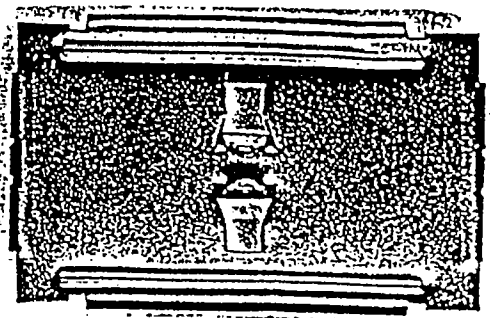

#499 '65-'66 rocker moulding clip.

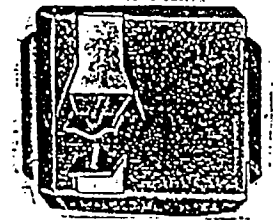

#500 -'56 300 side moulding clip.

MINIATURE LAMP

- #63 #1004
 - #57 #90
 - #67 #55
 - #1093 #87
 - #1157 #1157
- All \$.50 Cents each.

115. Convert. top cylinder base bushing up to '59, all cars

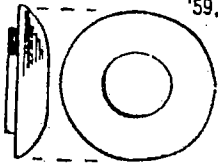

54. Convert. top header pin seal '57-'59

CONVERTIBLE ONLY PARTS

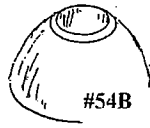

#54B '60-'64 convert. top pin seal. \$2.25

72. '60-'64 Convert. drain trough

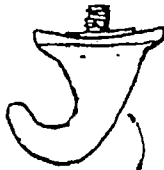

300. '58-'59 all conv. sun visor hook

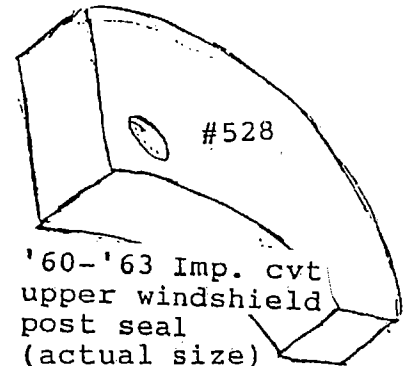
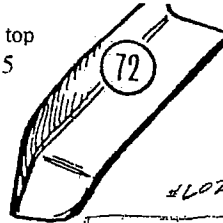

#528 '60-'63 Imp. cvt upper windshield post seal (actual size)

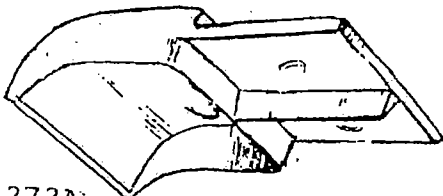

272A '41-'48 Plymouth Top-header-end seals. R&L

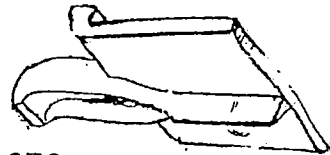

272B '39 Plymouth. Top-header-end seals. R&L

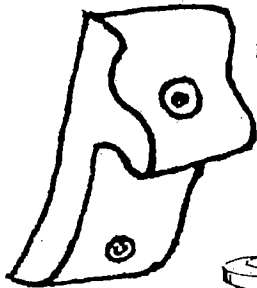

#389 '63-'66 A-body manual top catch (white)

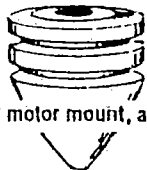

97. Convert top motor mount, all

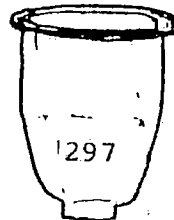

'63-'68 A-&B-body some C-body Cvt-top pin well



146 Flathead Phillips Machine Screw
A. 12-24x1... '57-'59 conv. top latch hooks to w/shield frame
B. 1/4 - 20x5/8 anti-rattle unit to door frame



311 Grommet that presses on cvt top well drain from the back side to hold it in place. Generally for '63&up cars.



#340 '57 Chrys., Desots conv. grommet for sunvisor end, goes in hole in header trim.

MORE ON NEXT PAGE

CONTINUED FROM
PREVIOUS PAGE

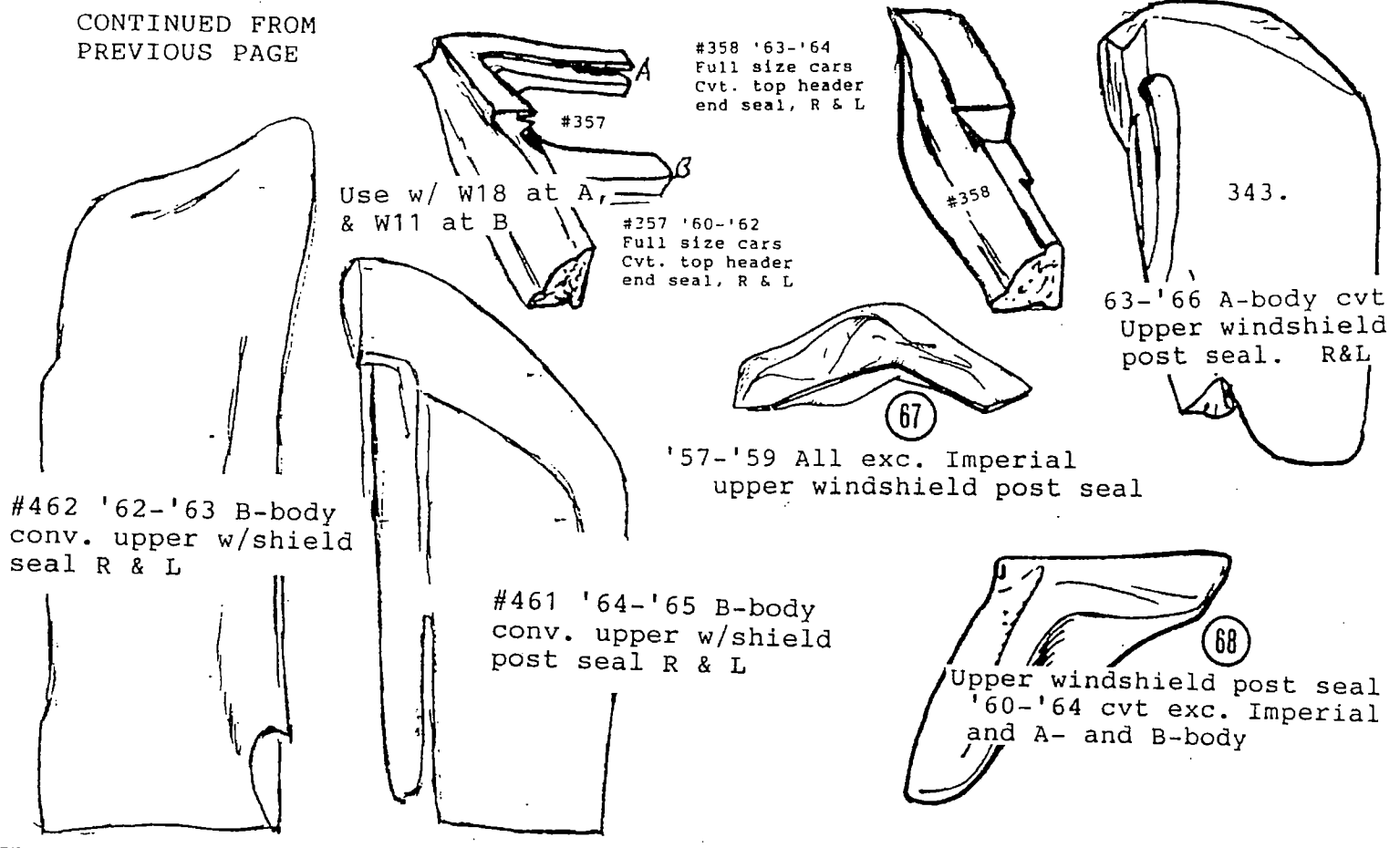

#462 '62-'63 B-body
conv. upper w/shield
seal R & L

Use w/ W18 at A,
& W11 at B

#461 '64-'65 B-body
conv. upper w/shield
post seal R & L

#358 '63-'64
Full size cars
Cvt. top header
end seal, R & L

#257 '60-'62
Full size cars
Cvt. top header
end seal, R & L

343.
63-'66 A-body conv
Upper windshield
post seal. R&L

'57-'59 All exc. Imperial
upper windshield post seal

Upper windshield post seal
'60-'64 cvt exc. Imperial
and A- and B-body

CONVERTIBLE SIDE RAIL WEATHERSTRIPS

W58	'55-'56 Chrysler	\$65set
W72	'55-'56 Dodge	\$65set
W12A	'57-'59 Chrysler	\$97set
W12B	'57-'59 Dodge, Ply.	\$97set
W75	'57-'63 Imperial	\$80set
W15/W76	'60-'64 Exc. A&B-body & Imperial	\$50set
W53/W90	'62-'65 B-body	\$50set
W53/W54	'63-'66 A-body	\$40set
W56/W57	'64-'68 Imperial	\$50set
	'65-'70 C-body	
	'66-'70 B-body	

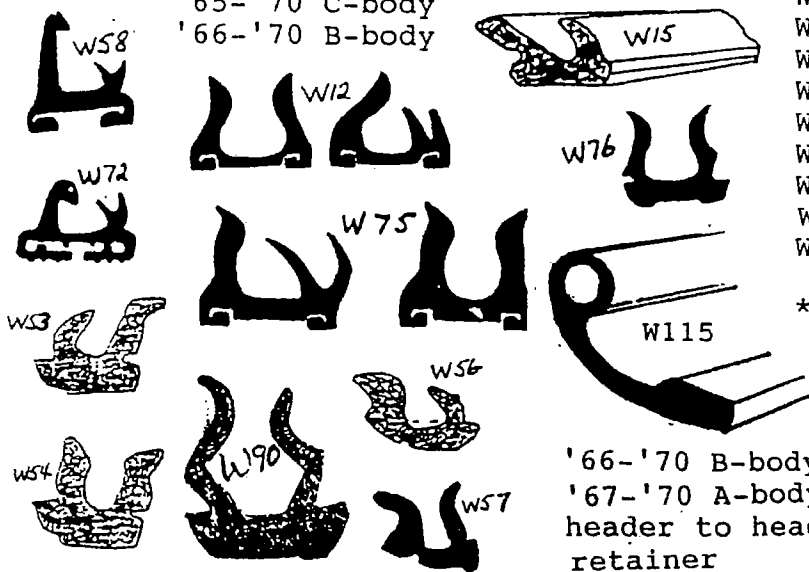

CONVERTIBLE TOP HEADER SEALS

W98*	'55-'56 Chrysler	\$45ea
W25	'57-'59 Lead/edge exc Imp.	\$25ea
W118*	'57-'59 Exc. Imperial	\$40 ea.
W108	'57-'63 Imp. lead/edge	\$28ea
W95*	'57-'63 Imperial	\$65ea
W11	'57-'63 General use	\$14ea
W18	'60-'64 All C-body	\$23ea
W97*	'62-'63 Dodge, Ply. B-body	\$55ea
W55	'63-'66 A-body	\$25ea
W93*	'63-'66 A-body	\$55ea
W55	'64-'65 B-body	\$25ea
W117*	'64-'65 Dodge, Ply. B-body	\$55ea
W116*	'64-'66 Imperial	\$55ea
W55	'65-'68 C-body	\$25ea
W96*	'65-'68 C-body	\$50ea
W79	'66-'70 B-body	\$28ea
W94*	'66-'70 B-body	\$50ea
W129*	'67-'69 A-body	\$50ea
W127*	'69-'70 C-body	\$55ea

* One-piece seals with molded ends

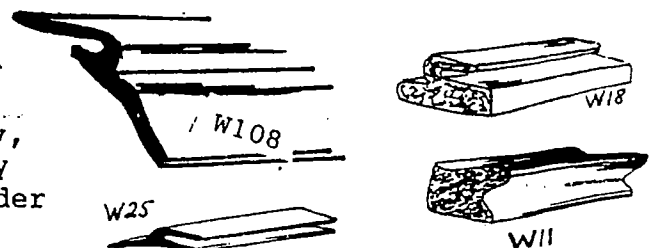

ROOF RAIL WEATHERSTRIPS FOR HARDTOPS

NEW! #RR3
some '59 H.T.
except Imperial.
Combination sponge
& solid extrusions
with molded ends.
\$68.00set

Seperate pieces must be
cut to length & super
glued

W128A	'65-'68 C-body 2 door hardtop	\$65 set
	With molded front tips	
W128B	'65-'68 C-body 4 door hardtop	\$65 set
	With molded front tips	
W12C	'57-'59 Chrysler, DeSoto 2 door	\$97 set
	Hardtop	
W12D	'57-'59 Dodge, Plymouth 2 door	\$97 set
	Hardtop. Most '59 Dodges take	
	W15 with #126 ends, see below	
W12E	'57-'59 all 4 door hardtops	\$97 set
W119	'55-'56 seal between roofrail	\$36 set
	Assembly and body	

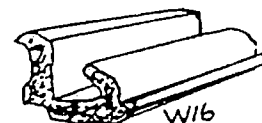
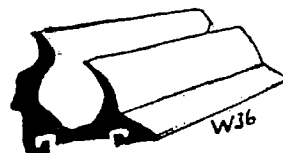
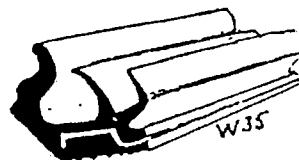
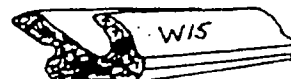

W91	'56 4 door hardtop	\$70.00 set
W35	'57-'59 Imperial 2dHT	\$75.00 set
	(top pieces only)	
W35/W36	'57-'59 Imperial 4drHT	\$85.00 set
W13	Some '59-'64 All C-body. Used	\$3.80ft
	over rear glass on some '59-'62.	
	Used on downward rear leg on '63-'64	
W15	Some '59-'64 All C-body. Used	\$3.80ft
	over door glass on all models &	
	over rear glass on some '60-'62.	
W53	'60-'66 Imperial all HT	\$3.90ft
W53	'60-'66 A-body HT over door glass	\$3.90ft
W53	'61-'65 B-body HT over door glass	\$3.90ft
W53	'67-'68 Barracuda over door glass	\$3.90ft
W54	'60-'66 A-body HT over rear glass	\$3.90ft
W54	'61-'65 B-body HT over rear glass	\$3.90ft
W54	'67-'68 Barracuda over rear glass	\$3.90ft
W74	'65-'70 All on windshield post	\$4.10ft
W16	'67-'70 All 2dHT over door glass	\$3.80ft
W73	'67-'70 All 2dHT over rear glass	\$3.80ft
W16	'67-'70 All 4dHT	\$3.80ft

ROOFRAIL WEATHERSTRIP ENDS AND UPPER WINDSHIELD
POST SEALS FOR HARDTOPS

* NEED OLD
METAL CORES

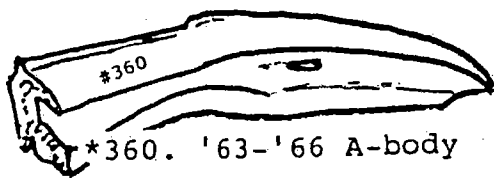

*360. '63-'66 A-body

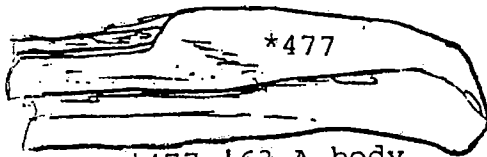

*477 '63 A-body

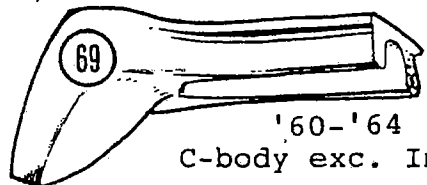

'60-'64
C-body exc. Imp.

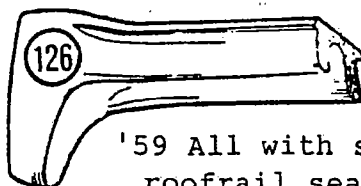

'59 All with soft
roofrail seal

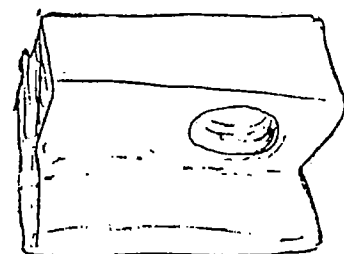

206A. '55-'56
Chrysler, DeSoto

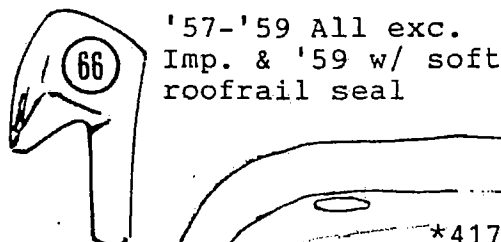

'57-'59 All exc.
Imp. & '59 w/ soft
roofrail seal



206B. '55-'56 Plymouth,
Dodge

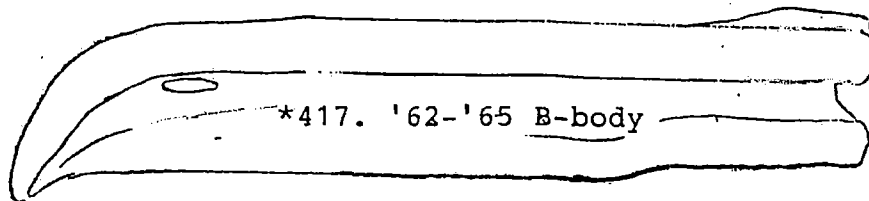

*417. '62-'65 B-body

The windshield and back glass seals listed below are extrusions-no molded corners. Unfortunately I lost my original manufacturer for these. I did get a good new manufacturer, but can't possibly afford to make all new dies for many of these which are very poor sellers, so I'll have to discontinue some as I run out of stock. The application listing is the best I could do. There are many models which take different seal profiles in the same year, so please check the crosssections against your originals. Molded seals were done, but the project turned into a nightmare. Go to page 50 for more info.

WINDSHIELD SEALS

All are priced \$85.00. Enough for one windshield.

- W40 '55-'56 All with snap-in outer stainless top trim
- W37 '55-'56 All bottom
- W37 '55-'56 All top & bottom if no snap-in top trim
- W37 '57-'59 All top except Imperial
- W39 '57-'59 All bottom except Imperial
- W37 '57-'63 All Imperial
- W37 '60-'64 All C-body
- W44 '63-'66 A-body bottom except cvt
- W45 '63-'66 A-body top except cvt.
- W44 '63-'66 A-body cvt.
- W83 '64-'65 B-body top
- W84 '64-'65 B-body bottom
- W47 '68-'70 A-body
- W52A "chrome" lockstrip for W44, W45, W46 \$24 ea.
- W123 '66-'68 C-body, '67-'68 Imp. top
- W124 '66-'68 C-body, '67-'68 Imp. bottom



BACKGLASS SEALS

All are priced \$85.00. Enough for one backglass.

- W40 '55-'56 All w/ inside metal trim & outer snapin trim, top and bottom
- W85 '55-'56 All w/o inside metal trim but, with outer snap-in trim, top and bottom
- W86 '55up All bottom w/ snap-in outer trim & straight rear edge of package shelf under weatherstrip lip
- W85 '57-'59 Top w/ snap-in outer trim & no inside trim
- W40 '57-'59 Chrys., Des. top with outer snap-in trim & inside trim
- W38 '57-'62 All bottom w/o snap-in outer trim
- W37 '60-'62 C-body top
- W28 '60-'66 Imperial Lebaron
- W50 '63-'64 Chrysler top
- W51 '63-'64 Chrysler bottom
- W45 '63 Dart, '63-'66 Val. HT & Sdn. top
- W46 '63 Dart, '63-'66 Val. HT & Sdn. bottom
- W42 '64-'66 Dart all bodies HT & Sdn. top
- W43 '64-'66 Dart all bodies HT & Sdn. bottom
- W48 '68-'69 A-body HT bottom
- W49 '68-'69 A-body HT top
- W52 "Chrome" lockstrip for W45, W46, W44, \$24each

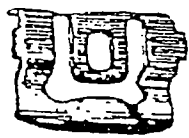
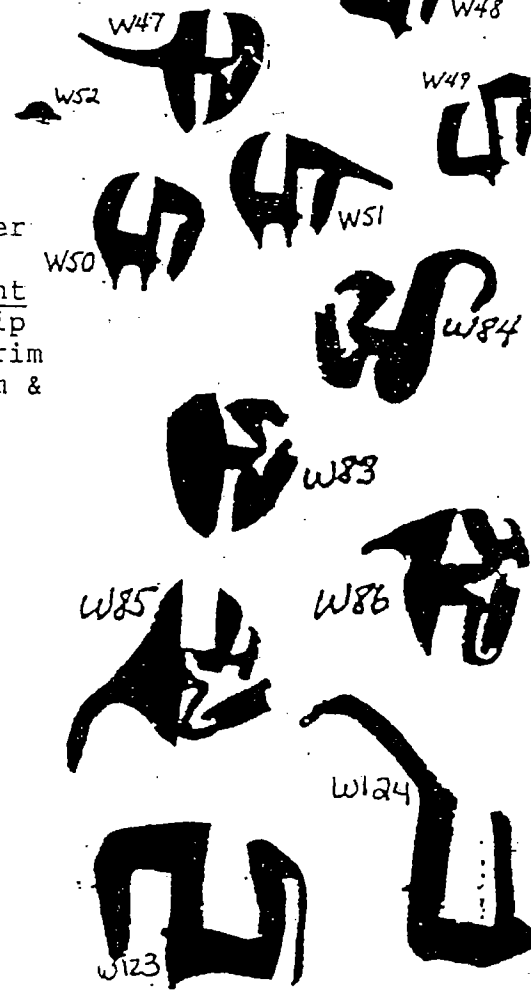

507. W/shield & rear window reveal mldg. clip. side & upper: Dodge, Ply., Dart '67,'68

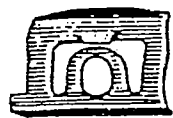

506. Windshield outside mldg. retainer. '68/ Chrys. prod.

NEW! Super windshield and backglass seals. One piece high quality highly detailed seals with molded corners. All are priced \$90each.

All are for HTs. & Sdns unless otherwise noted.

WINDSHIELD SEALS

- WS103 '62-'63 Dodge/Ply. B-body
- WS102 '63-'66 Dart/Val. HTs, Sdns
'64-'66 Barracuda
- WS100 '64 Belvedere, Fury, Savoy,
Dodge 330/440, Polara/500,
- WS100 '65 Belvedere, Coronet,
Satellite
- WS104* '66-'70 Dodge B-body Cvts,
Plymouth B-body Cvts
- WS101 '68-'70 Belvedere, Charger,
Coronet, Roadrunner, Satellite,
Superbee
- WS101 '69 Daytona, '70 Superbird

BACKGLASS SEALS

- WS102R '64-'66 Barracuda,
- WS100R '64-'65 Belvedere, Coronet,
Dodge 2dHTs, Fury, Ply. 2dHTs,
Polara, Satellite 2dHTs & Sdns.

TOOLS AND SUPPLIES

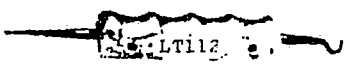

A special handle and insert tool for installing self locking one-piece rubber. Also excellent for installing rubber channels with a lip. Insert tool between the locking lip and its groove. Then, by moving the tool along the groove, the rubber lip locks in position.

\$21.50

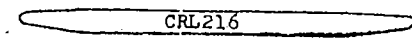
64750
Inserts the locking strip around windshields and other windows. \$15.25

CRL216
Plastic insert tool eases installation of glass into rubber channels and gaskets. Tapered ends slip in easily, and tool won't chip or scratch glass. Also good for installing sealants. \$1.50

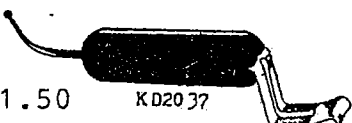
GP228
Tool designed to speed closing of self-sealing windshield and back glass rubber. \$13.25

K02037
\$11.50

One end of this tool spreads rubber zipper type gaskets. The other end removes "standard" Chrysler clips.

CONTACT CEMENT

A high quality fast drying general trim adhesive used to glue leather, weatherstrips, vinyl, carpet etc.
AD102A Quart \$6.70 AD102B Pint \$4.10

EVERSEAL GLASS SETTING TAPE

Easy to install, this tape retains its strength and flexibility indefinitely. If a light oil is applied to it or the sidewalls of the channel, installation is made simpler and the tape will swell after setting and provide a permanent cushion for the glass.

Cat. #	Thickness	Width	Cost per Ft.
ES15116	1/16"	1-1/2"	.35¢
ES15132	1/32"	1-1/2"	.25¢
ES15332	3/32"	1-1/2"	.45¢
ES15364	3/64"	1-1/2"	.30¢

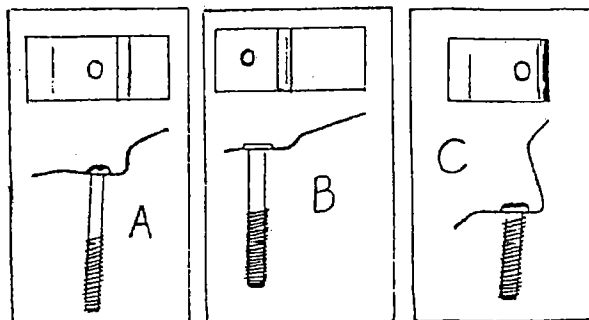

#490 '57-'59 all except Imperial windshield & backglass lower molding fastener. Complete set of 16 ... \$34.00
A. Windshield center 5 clips ... \$2.25 ea.
B. Windshield end clips (4) ... \$2.25 ea.
C. Backglass: all 7 are the same ... \$2.25 ea.

GLASS POLISHING ASSEMBLY

Complete with 1/4" shank.

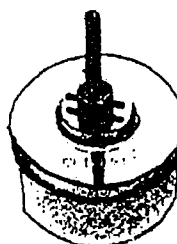

Made of highest quality white Spanish felt. 3 inch diameter by 1 1/2 inch thick. Wheel should be trued before each operation by gently running on medium grade sandpaper.
5703 \$28.50

CERIUM OXIDE

High quality, optical grade polishing compound.
CO405 \$8.75

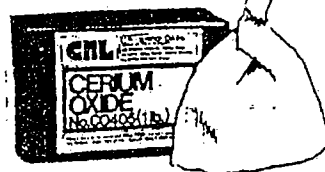

*It just had to happen--blank space to fill and nothing to put here. So, let me take this opportunity to remind you once again to send in your cores for gas and brake pedals, gap fillers, colum seals etc. with your order. Sure cuts down on a lot of hassle. Be sure to check out the new reproduction lenses and chrome. Really nice stuff!
A note on this page. Some of these tools may not be available much longer and those that are available seem to be made of gold when I order them. I'll try to keep them in stock.*

DECALS

Illustrations are not actual size



226

226. 300 E valve cover



217. '57 & later P/S pump.



222. Fuel filter. '59 & later

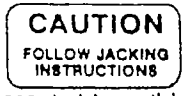

232. Jack base sticker.



227

227. '58 & later Auto Pilot. Alum.



233. '55 300 fr. & rear medallion. Set

267



300H seat belt sticker \$3.00
3 color embossed foil

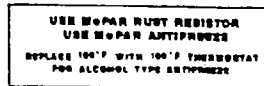

219. Core support.

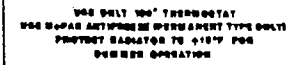

220. Cor support.

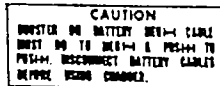

221. Core support

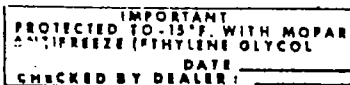

218. Core support.

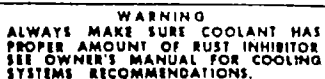

269. '56 Chrysler booklet

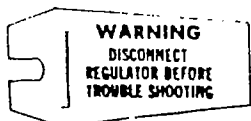

262. Red tag for all alternators

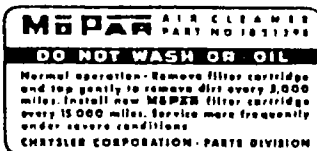

223

223. '57-'62 single, '57 dual



216

216. '63 & later single carb.

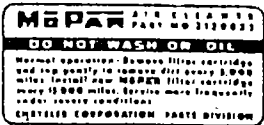

225. All with ram manifold.

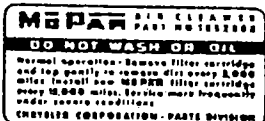

224. '58, '59, '62 dual carbs.



260. Back light decal all A/C cars

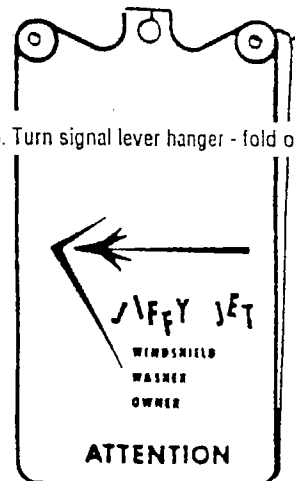

266. Turn signal lever hanger - fold out

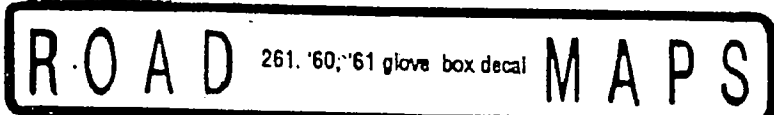

261. '60, '61 glove box decal

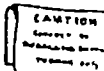

230. Reg. condenser wire tag. Red paper

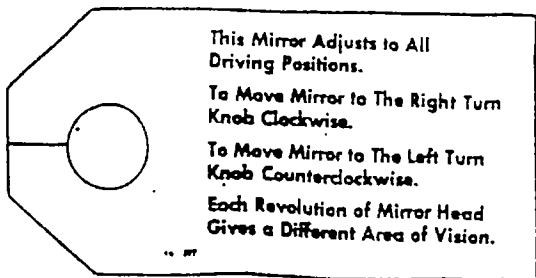

270. '58, '59 remote control mirror tag



229. Gen. field term. tag. Red paper

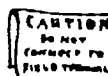

231. Gen. condenser wire tag. Red paper

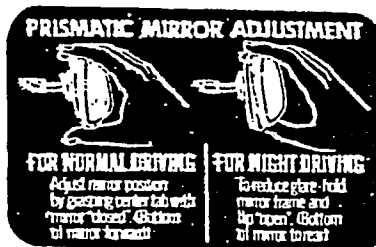

#332 Rear-view mirror sticker

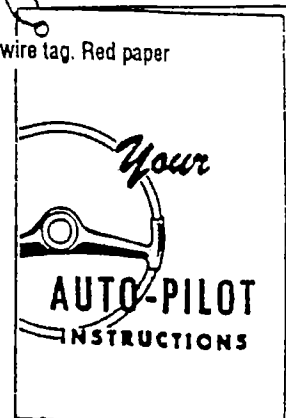

268. Auto-Pilot hanger



335A. Golden Lion 383

335B. golden Lion 413

'59-'61 Chrysler valve cover decals

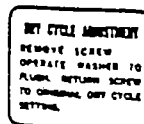

265. '60 windshield reservoir stickers

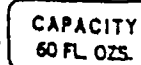

264

Decals !

Excellent reproductions, clear printing, neatly cut edges. Many not found elsewhere (until they copy these!) See pages 37 & 38 in catalog for more. Most decals are shown smaller than actual size.

Replacement for stamped printing on coils. These are printed on clear stock as an easy way to have your coil look original without all the mess and expense of trying to ink stamp it. According to the parts books #570 is for '56-'58, #571 is for '59-'63, and #572 is for '64 and up. Many of the #570 versions have been seen on cars later than '58, so you be the judge of which you want. Doesn't seem to be any distinct cutoff dates.

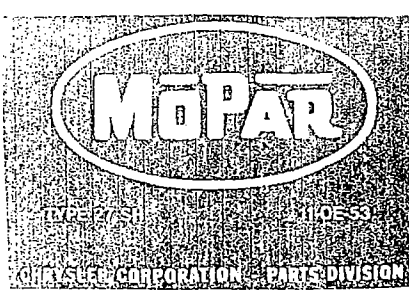

#587A - A sticker for battery to give it a more original look. This one is for the big battery (series 27) for years '56-'58. 6 1/4" x 3 3/4" \$5.00

#587B - Same as above, but for smaller battery (series 24) 6 1/4" x 3 3/4" ... \$5.00

#588A - '59-'62' battery sticker for 27 series 6 1/4" x 3 3/4" \$5.00

#588B - Same as above for 24 series. 6 1/4" x 3 3/4" \$5.00

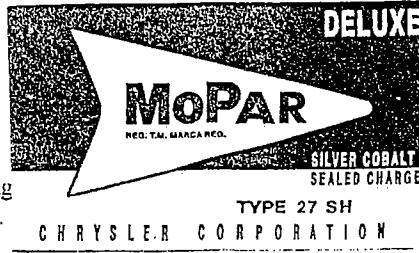

Note: New cars were not delivered with MoPar batteries! The MoPar stickers were on replacement batteries. Also there doesn't seem to be a consensus as to exactly what years the different stickers were on, so which ever one turns you on basically.

BAT. 12V. DIST. USE WITH EXTERNAL RESISTOR
PART NO 1688212
AUTO-LITE CAH-4001

#570 - \$4.00

BAT. 12 V. DIST. USE WITH EXTERNAL RESISTOR

2444242
CH-412
2495531

#572 - \$4.00

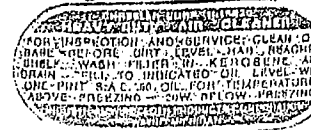

#574 - Small oil bath air cleaner decal used on '55-'56, but not the "bat wing" units..... \$4.00



#575 - '56 and earlier power steering pump reservoir..... \$3.00

BAT. 12V. DIST. USE WITH EXTERNAL RESISTOR
PART NO. 2095223
ESSEX 67-160-2

MADE IN USA.

#571 - \$4.00

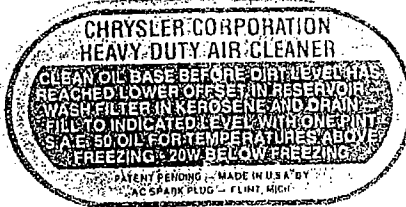

#573 - Large oil bath air cleaner decal used on almost everything from '37-'54 \$4.50



#577 - '56 and earlier (maybe a year or two later) oil filler cap (this was taken off an original '56 DeSoto) \$4.00

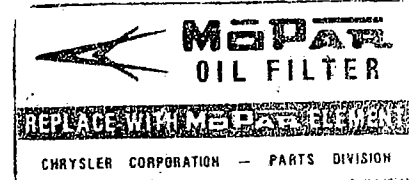

#582 - '57-'58 oil filter canister.... \$3.00

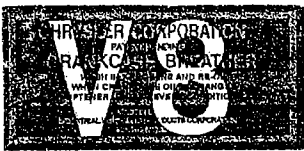

#576 - '56 and earlier crankcase breather (oil filler tube) cap..... \$4.00



#581 - '55-'56 oil filter canister..... \$3.00

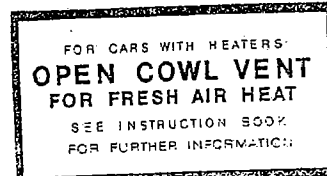

#580 - '55-'56 attached to inside of glove box door... \$3.50



Your car has been equipped with four Goodyear Captive-Air safety tires. Because you have this special equipment, there is no requirement for a spare tire. Service instructions and the guarantee covering these tires has been placed in the glove box of your car. You may consult this literature or your dealer for further information.

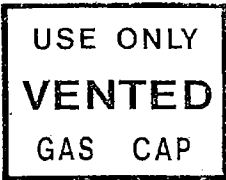

#579 - '55-'56 gas door. \$3.50

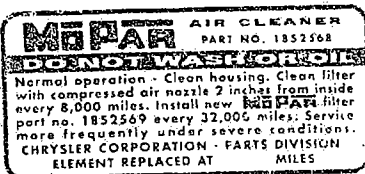

#584 - '62 dual carb air cleaners-slightly different wording than #224, but same size..... \$2.00



#583 - '59 Plymouth air cleaner.....\$6.00



#592 - Decal for Imperial trunk lid handle. '57-'59 (see CHR76, page 47 for new handle) larger than actual size ... \$4.00

#586 - Sticker found on a '60 Chrysler driver's door opening (by latch plate) for Captive air tires..... 3 3/4" x 3 3/4" \$7.00

These tires were commonly used on the line 9 passenger Station Wagons in '59 and a few later years and probably earlier. If your '57-'58 wagon doesn't have a provision for a spare, that's the clue -- it had captive-air tires.

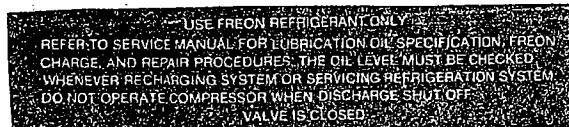

#589 - Red on foil sticker for early A/C compressor (not V type) '55 era \$6.00

CAUTION
BOOSTER OR BATTERY NEG (-) CABLE MUST GO TO NEG(-) & POS(+) TO POS (+) DISCONNECT BATTERY CABLES BEFORE USING CHARGER.

#585 - '60 and later battery caution label for core support. This one is a little thinner and slightly different. Layout than #221\$3.00



#578 - '55 and maybe earlier coil. \$4.00

'59 Dodge valve cover decals
#533

WARNING
DO NOT SHORT ANY
TERMINALS TO GROUND
WARNING
Q33 2098300

#473 Decal for early
alternator voltage
regulators



D•500

SUPER RED RAM

#593 - '55-'57 Dodge hemi valve cover.
11 1/4" long \$18.00 set of 2

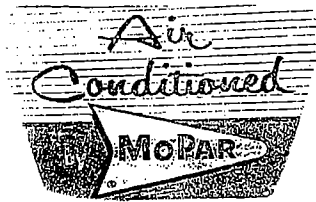
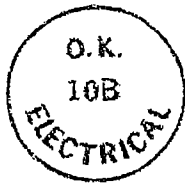

#594 - Rare and unique decal found on
top of heater case on car equipped
with dealer added MoPar A/C
This was a '60, but my guess would
be '57-'64 ... 4 1/2"x 3" \$7.00

#599 - At last! No more pain in the *** ink stamps to mess with.
These yellow on clear stickers replace those original ink
inspection stamps. They look great on black, so no problem
On other colors. Cut right to the border for clean appearance.
\$9.00 set of 3

**UN-ZIP REAR WINDOW
BEFORE LOWERING TOP**

#596 - Another rare and unique sticker. Black
on silver sticker goes on convertible
windshield header (top) trim..... \$5.00

**WIPER - WASH
LIGHTS - PANEL
TUNING
IGNITION
OFF ON VOL**

#595 - Black on clear set of stickers to
replace painted printing on '60
Chrysler dash aluminum. Scratched
and dented originals can be carefully
restored with some care pressing out
dents and then duplicating the brushed
look with 80 grit sandpaper carefully
applied in one direction. These
individually cut stickers look just like
the Original printed words once firmly
applied. It will be a little tricky getting
them perfectly straight so I'm sending
two sets with each order..... \$6.00

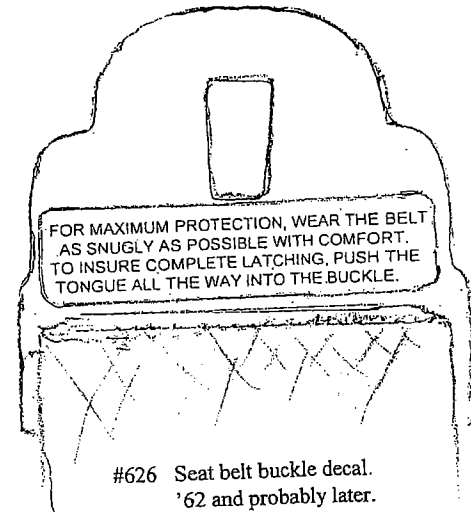

#626 Seat belt buckle decal.
'62 and probably later.
\$2.00



#597 - '59-'62 Imperial valve cover sticker
\$18.00 set

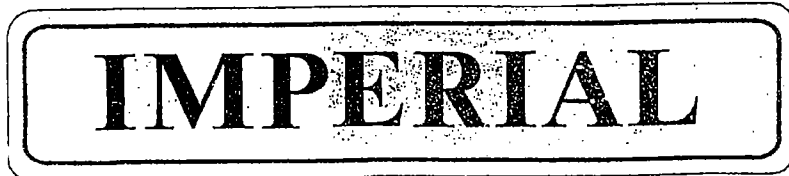

#598 - '63-'66 Imperial valve cover sticker
\$14.00 set
Note: Not totally certain on the cutoff year on #597
or the starting year on #598. I'm sure you
Imperial nuts know! These are real nice crisp
quality, not like some others I've seen.

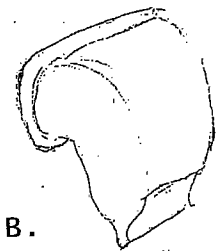

#41 B.

Early '57 car owners!
Do your heater drains look
something like this? Or-do
you have some crusty remnants
of rubber clinging on an oval
ring that snaps onto the hole?
You're in luck! No, I can't
reproduce the original type --
out of sight expensive. So, I
made a slightly larger version
of #41 (see catalog page #21)
This is what was used on most
'57's and continued through '64
(because they worked!) Just drill
two holes, bend in the upper
edge of the hole a little and pop
them in. Order #41B same price
As #41

J9 \$5.00.

**JACKING INSTRUCTIONS
FOR
"SURE-GRIP" DIFFERENTIAL**
When one rear wheel is raised
from the ground, be sure the engine
is shut off. Before raising a rear
wheel, always have the diagonally
opposite wheel blocked against
forward or backward motion.

GASKETS etc.

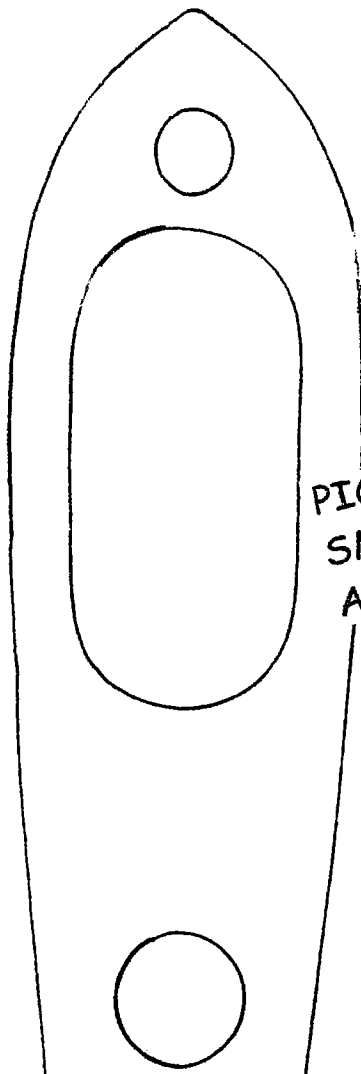

291. '57-'59 Dodge rear antenna base gasket

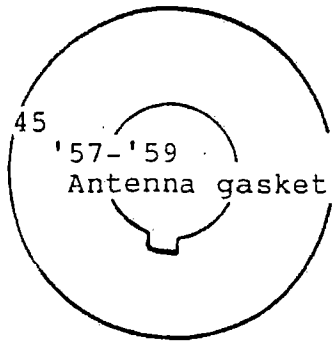

45 '57-'59 Antenna gasket

PICTURED ABOUT 10%
SMALLER THAN
ACTUAL SIZE

301. '57-'58 Plymouth, Dodge mirror gasket

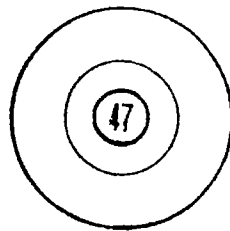

47

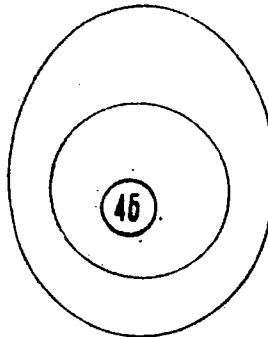

46

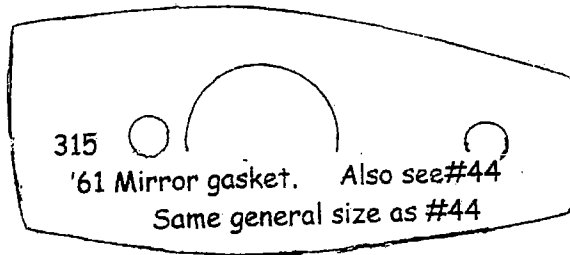

315 '61 Mirror gasket. Also see #44
Same general size as #44

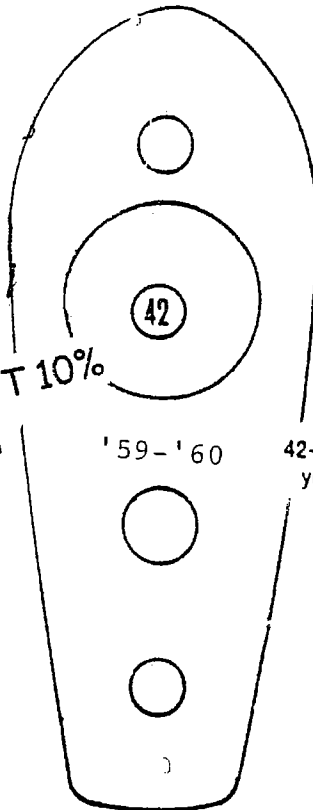

42

'59-'60

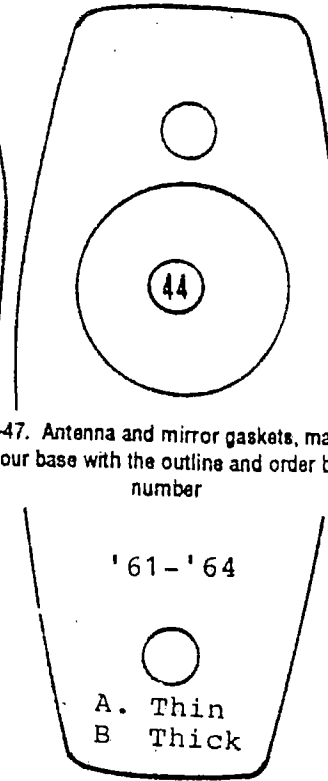

44

'61-'64

A. Thin
B. Thick

42-47. Antenna and mirror gaskets, match your base with the outline and order by number

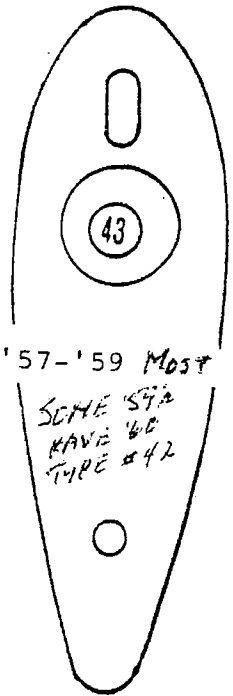

43

'57-'59 Most

SOME STA
HAVE 48
TYPE #42

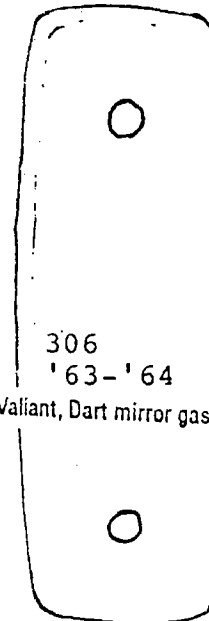

306
'63-'64

Valiant, Dart mirror gasket

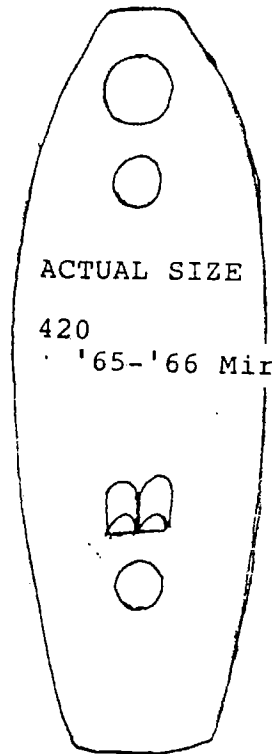

ACTUAL SIZE

420

'65-'66 Mir:

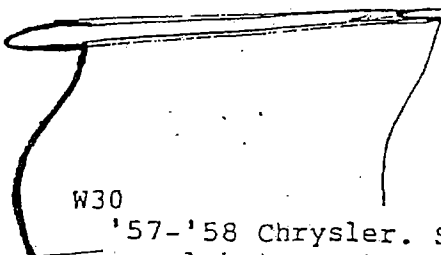

W30

'57-'58 Chrysler. Special seal between tail light filler and bumper \$8.90pr.

W106

Rubber edging (actual size)
Goes around edge of metal spare tire cover '57-'62. Many general uses
see #W107 \$1.70/ft

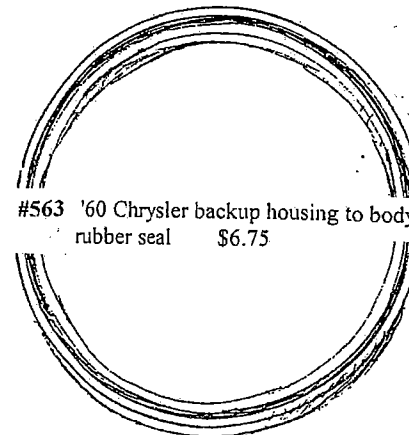

#563 '60 Chrysler backup housing to body rubber seal \$6.75

MORE ON NEXT PAGE

REMOTE MIRROR & ANTENNA GROMMETS

#94B New! repro plastic base (dotted line)

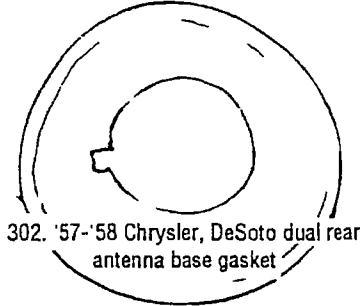

302. '57-'58 Chrysler, DeSoto dual rear antenna base gasket

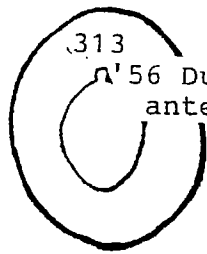

313 '56 Dual rear antenna gasket

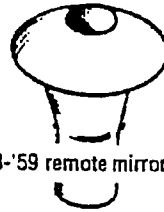

205. '58-'59 remote mirror grommet

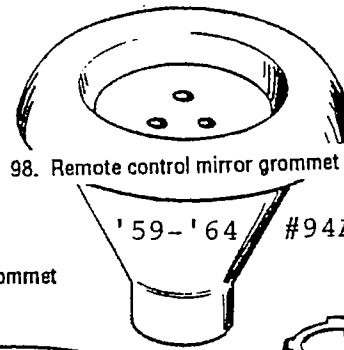

98. Remote control mirror grommet

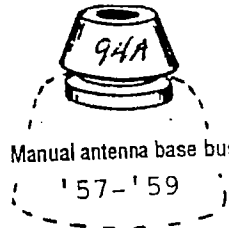

#94A Manual antenna base bushing '57-'59

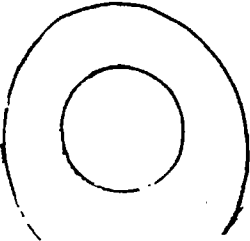

288. '55 Antenna base gasket.

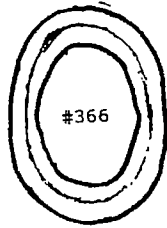

#366 '61-'63 Imp. headlight rear stanchion

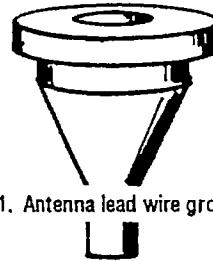

51. Antenna lead wire grommet '57-'59

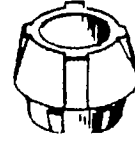

96. Antenna lead wire grommet '55, '56

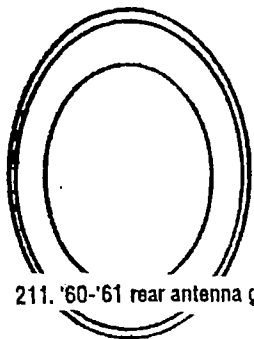

211. '60-'61 rear antenna gasket

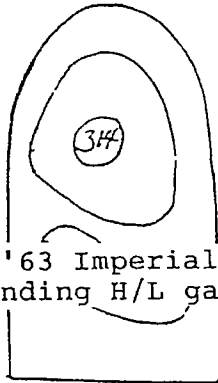

314 '61-'63 Imperial Standing H/L gasket

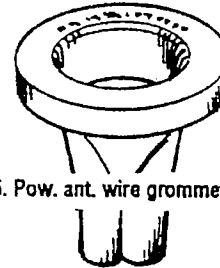

235. Pow. ant. wire grommet '57-'59



234. Man. antenna wire grommet '65

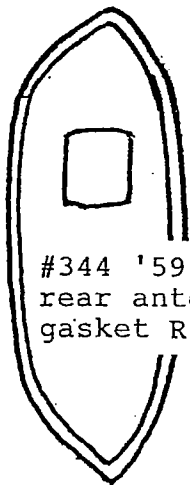

#344 '59 Desoto rear antenna base gasket R & L



W131 Rubber edging for '64 Dart, Dodge, Chrysler taillight housings and other applications. \$1.50 ft.

'62 Chrysler T/L housing seal (Rubber on edge of chrome housing)

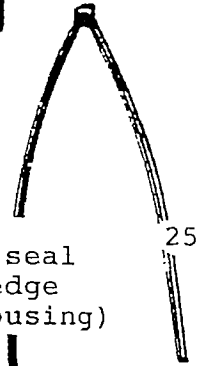

258

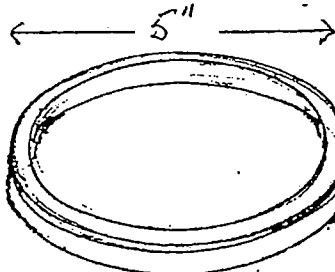

#465 '59 Dodge taillight housing to body seal. (Rubber seal on outer edge)

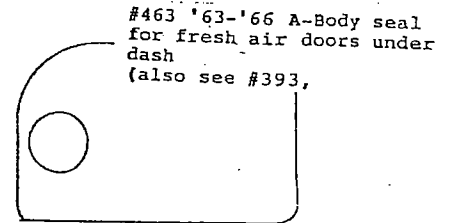

#463 '63-'66 A-Body seal for fresh air doors under dash (also see #393,

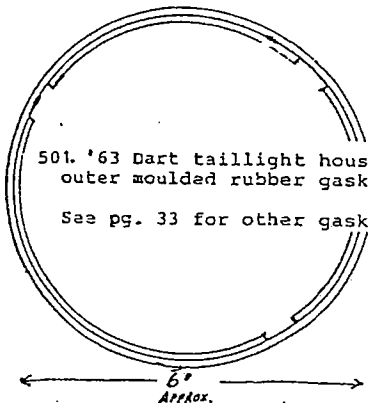

501. '63 Dart taillight housing outer moulded rubber gasket. See pg. 33 for other gaskets.

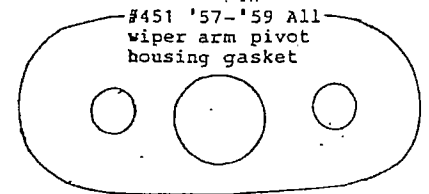

#451 '57-'59 All wiper arm pivot housing gasket

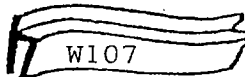

Rubber edging general use- see #W106 \$1.80/ft

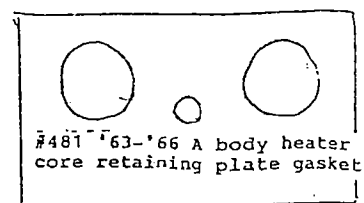

#487 '63-'66 A body heater core retaining plate gasket

LENS AND HOUSING GASKETS

Tired of cutting out strips of cheap junk to seal your lenses? Here's the cure. Die cut gaskets made from high quality gray sponge neoprene. This 3/16" material fits, seals and lasts.

TAIL LIGHT LENS GASKETS

TG28	'50 DeSoto	\$2.50
TG1	'55 Chrysler	\$3.00
TG29	'56 DeSoto	\$3.50
TG30	'56 Plymouth	\$3.00
TG2	'56 Chrysler	\$3.50
TG3	'57 Chrysler	\$3.50
TG25	'58-'59 DeSoto, 6 required	\$1.65
TG36	'57-'59 Imperial	\$2.50
TG4	'58 Chrysler	\$3.50
TG32	'58 Dodge	\$2.50
TG10	'58 Plymouth	\$2.50
TG5	'59 Chrysler	\$2.50
TG38	'59 DeSoto	\$2.50
	6 needed including backup lens	
TG39	'59 Dodge	\$3.00
TG11	'59 Plymouth J-lens	\$3.50
TG6	'60 Chrysler	\$3.50
TG16	'60 Dodge	\$3.00
TG7	'61 Chrysler	\$4.00
TG34	'61 Imperial front	\$2.50
TG35	'61 Imperial rear	\$2.50
TG8	'62 Chrysler	\$3.50
TG37	'62 Imperial	\$2.50
TG33	'62 Plymouth	\$2.50
TG12A	'63 Dart inner	\$2.50
TG12B	'63 Dart outer	\$1.90
TG17	'64 Chrysler	\$2.75
TG9	'64-'65 Barracuda	\$2.75
TG31	'64 Dodge B-body	\$3.00
TG13	'64 Dart	\$2.50
TG14	'65-'66 Dart	\$2.50
TG9	'65 Valiant	\$2.50
TG15	'66 Valiant	\$2.50
TG27	'66 Valiant reflector	\$2.00
TG18	'68 Charger	\$2.50
TG23	'68 Dart	\$2.80
TG21	'68 Satellite	\$3.25
TG24	'69 Coronet	\$3.00
TG22	'69 Road Runner	\$3.50
TG20	'70 Charger	\$3.00
TG19	'70 Coronet	\$3.00

LICENSE LIGHT GASKETS

LG1	'57-'58 Chrysler	\$2.50
LG1	'57-'58 DeSoto	\$2.50
LG5	'57-'58 Imperial	\$2.50
LG2	'59 All makes exc. Imperial	\$2.50
LG3	'60-'62 Chrysler	\$2.50
LG3	'60-'61 DeSoto	\$2.50
LG6	'61 Imperial	\$2.50
LG4	'62 Plymouth	\$2.50
LG7	'64 Plymouth	\$2.50

PARKING LIGHT LENS GASKETS

PG1	'55-'56 Chrysler 300	\$2.50
PG9	'55-'56 Imperial	\$2.50
PG30	'56 Chrysler New Yorker	\$2.50
PG2	'57 Chrysler	\$2.50
PG5	'57 DeSoto	\$2.50
PG2	'58-'59 Chrysler 300	\$2.50
PG33	'58 Dodge	\$2.60
PG10	'58 Plymouth	\$2.50
PG34	'59 Chrysler New Yorker	\$2.25
PG6	'59 DeSoto	\$2.50
PG27	'59 Imperial	\$2.50
PG3	'60 Chrysler	\$2.50
PG29	'60 DeSoto	\$2.50
PG7	'60 Dodge	\$2.50
PG4	'61-'62 Chrysler	\$2.60
PG28	'61-'62 Chrysler housing	\$2.00
PG4	'61 DeSoto	\$2.50
PG32	'62 Plymouth	\$2.50
PG11	'63-'64 Chrysler	\$2.50
PG14	'63-'64 Dart	\$2.00
PG15	'63-'64 Dart housing	\$1.75
PG11	'63 Plymouth	\$2.50
PG16	'65 Dart	\$2.50
PG8	'65 Valiant	\$2.50
PG17	'66 Dart	\$2.75
PG13	'66 Valiant	\$2.50
PG22	'68 Dart	\$2.50
PG18	'68 Satellite	\$2.50
PG24	'69 Chrysler	\$2.50
PG20	'69 Barracuda	\$2.50
PG23	'69 Dart	\$2.50
PG18	'69 Road Runner	\$2.50
PG26	'70 Challenger	\$2.50
PG21	'70 Coronet	\$2.50
PG19	'70-'72 Duster	\$2.50
PG25	'73-'74 Duster	\$2.50

BULK GENERAL PURPOSE GASKET MATERIAL

1/16" neoprene impregnated, sq/in	\$0.06
3/16" gray sponge neoprene, sq/in	\$0.05
3/16" black sponge neoprene, sq/in	\$0.05
1/2" black sponge neoprene, sq/in	\$0.07
1" black sponge neoprene, sq/in	\$0.10
Please specify the size you need. I've priced it per square inch so you only buy what you need.	

BACKUP LIGHT LENS GASKET

BG6	'55 Imperial	\$2.50
6	'56 Crown Limo	\$2.50
TG29	'56 Desoto	\$2.50
BG5	'56 Imperial	\$2.50
BG13	'56 Plymouth	\$2.50
TG25	'57-'58 Desoto	\$1.75
BG14	'57-'59 Imperial	\$2.50
BG1	'59 Chrysler	\$2.50
TG38	'59 DeSoto	\$2.50
BG2	'60 Chrysler	\$2.25
BG16	'60-'62 Imperial	\$3.00
BG3	'61 Chrysler	\$2.25
BG9	'62 Chrysler	\$2.75
BG15	'62 Dodge	\$2.50
BG7	'63-'64 Dart	\$2.50
BG4	'64-'65 barracuda	\$2.50
BG17	'64 Plymouth	\$3.00
BG4	'65 Valiant	\$2.50
BG11	'66 Valiant	\$1.75
BG12	'66 Valiant hsg	\$3.50
BG10	'69 Charger	\$2.50

TAIL LIGHT HOUSING-TO-BODY GASKETS

HG1	'55 Chrysler	\$2.00
HG6	'56 Chrysler	\$2.50
HG22	'56 Desoto	\$1.25
HG2	'57-'58 Chrysler	\$1.25
HG23,	'57-'58 DeS. <u>Needs 6 ea.</u>	\$1.25
HG15	'58 Imperial	\$2.25
HG3	'59 Chrysler	\$1.50
HG25	'59 Desoto <u>Needs 6 ea</u>	\$1.50
HG4	'60 Chrysler	\$2.00
HG28	'60-'62 Imperial	\$4.00
	bu/hsg-body	
HG5	'61 Chrysler	\$3.50
HG9	'Chrys,lamp Fix.to hsg	\$2.00
HG2	'61 Chrysler. Fix to Bdy	\$2.00
HG7	'62 Chrysler	\$3.00
HG8	'62 Chrysler	\$2.00
	bu/hsg-body	
HG24A	'63 Dodge (large)	\$3.50
HG24B	'63 Dodge (small)	\$2.00
HG11	'63 Dart	\$2.50
HG27	'63-'64 Dart	\$2.25
	bu/hsg-body	
HG10	'64 Chrysler	\$1.50
HG26	'64 Dodge (moulded)	\$6.50
HG12	'64 Dart	\$2.50
HG13	'56 Dart	\$2.50
HG30	'66 Dart (moulded)	\$6.50
HG29	'65 Satellite	\$3.50
HG21	'65 Valiant	\$3.00
HG14	'66 Valiant	\$2.50
HG20	'68 Dart	\$3.50
HG18	'68 Satellite	\$3.50
HG18	'68 Roadrunner	\$3.50
HG19	'69 Roadrunner	\$3.50
HG17	'70 Challenger	\$5.50
HG16	Coronet	\$3.50

SUSPENSION

FRAME & BRAKE PARTS

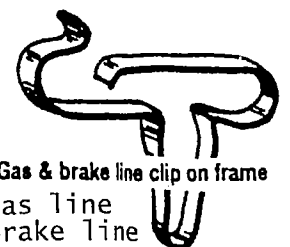
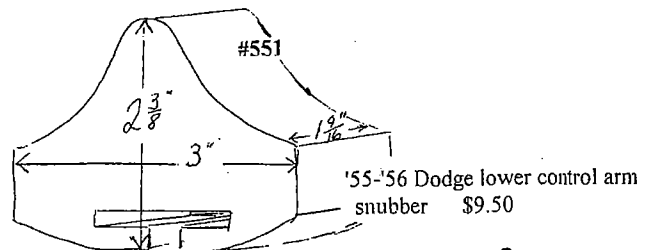
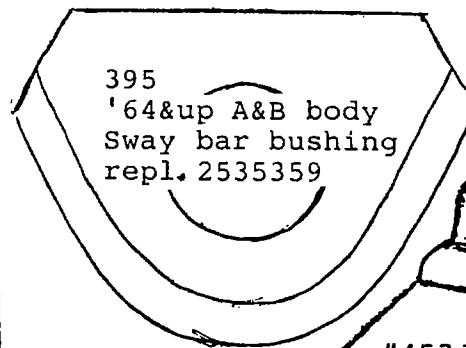
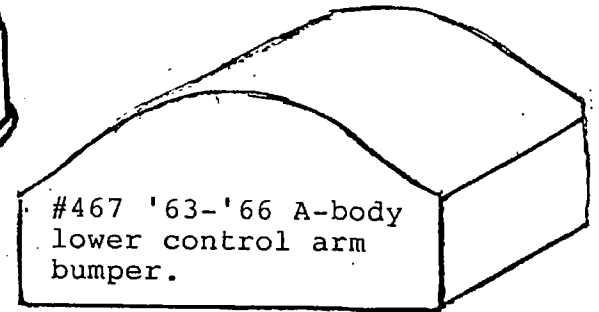
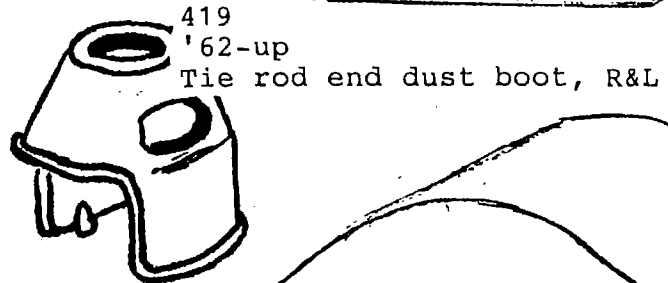
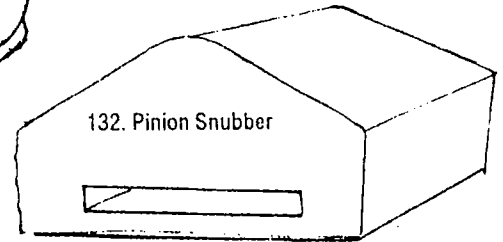
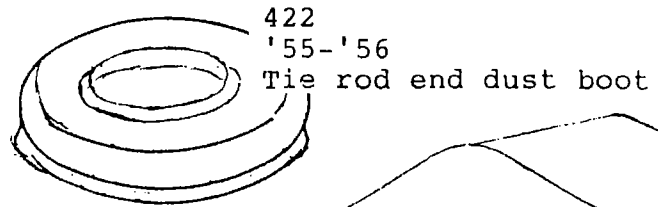

MORE ON NEXT PAGE

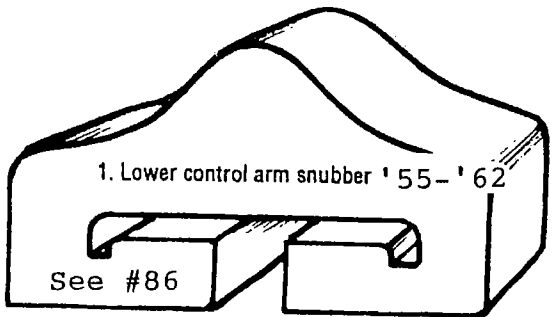

1. Lower control arm snubber '55-'62

See #86

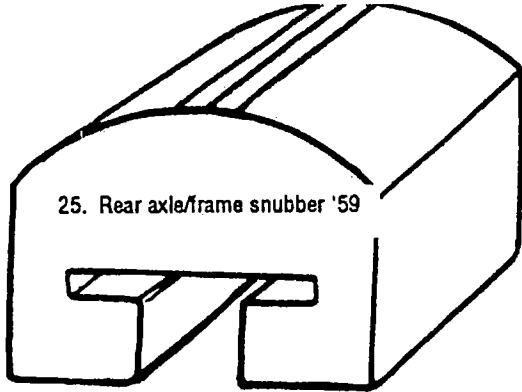

25. Rear axle/frame snubber '59

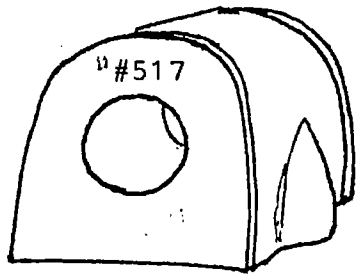

#517

#517 '55-'56 Sway bar bushing

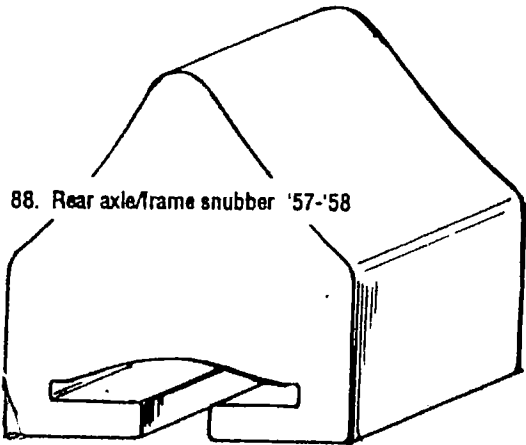

88. Rear axle/frame snubber '57-'58

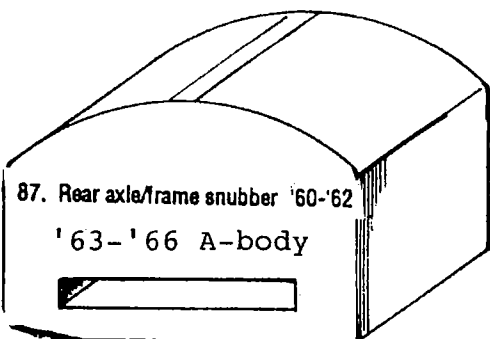

87. Rear axle/frame snubber '60-'62 '63-'66 A-body

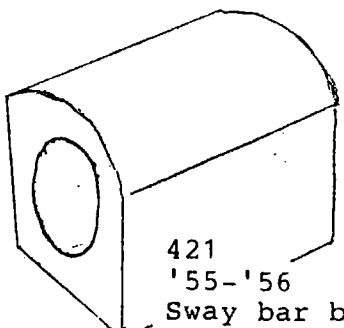

421 '55-'56 Sway bar bushing

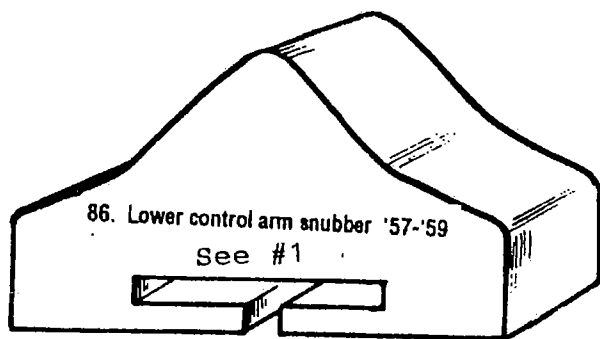

86. Lower control arm snubber '57-'59 See #1

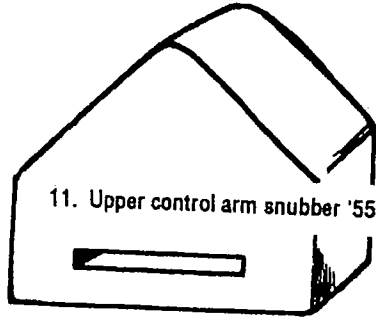

11. Upper control arm snubber '55, '56

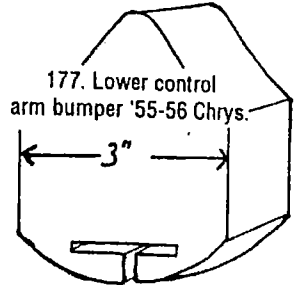

177. Lower control arm bumper '55-'56 Chrys.

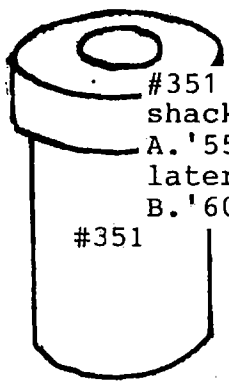

#351 Rear spring shackle bushing A. '55-'64 maybe later C-body B. '60-'74 A-body

#351

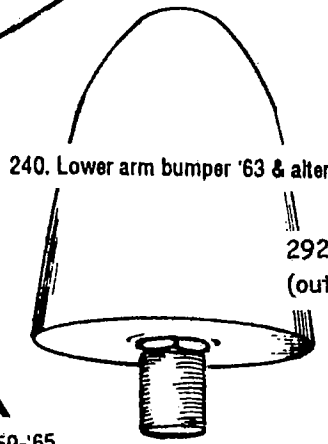

240. Lower arm bumper '63 & alter

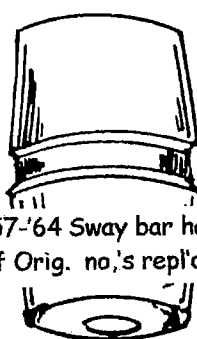

292. '57-'64 Sway bar hanger upper bushing (out of Orig. no.'s repl'd with good 2 pc units)

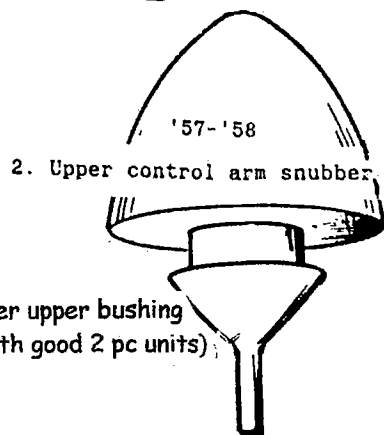

'57-'58 2. Upper control arm snubber

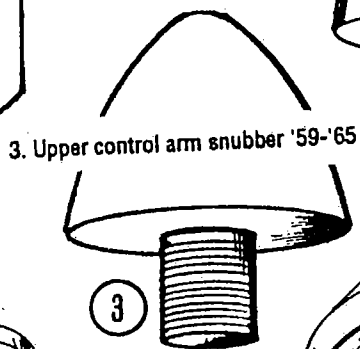

3. Upper control arm snubber '59-'65

3

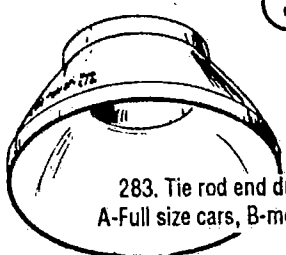

283. Tie rod end dust boot; A-Full size cars, B-medium size.

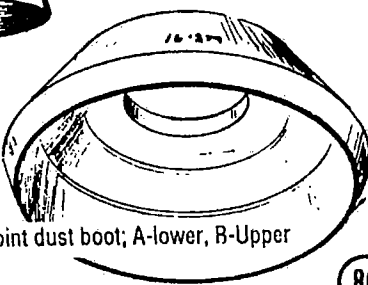

286. Ball joint dust boot; A-lower, B-Upper



#80 '57-'65 Sway bar bushing A. 3/4" hole (most common) B. 5/8" hole C. 7/8" hole

80

80-81. Sway bar bushings '57-'65

Rubber only See also #292

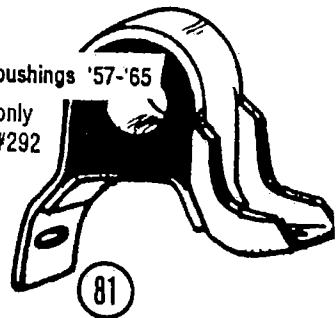
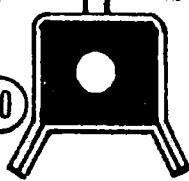

81

BRAKE PARTS

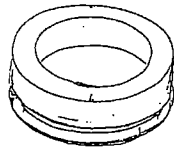

'57-'62 lockhead brakes
11"x2" brake shoes \$36.00 per
axle set.

#605 '57-'59 except Imperial
gas tank filler tube top
seal. \$12.00

#527

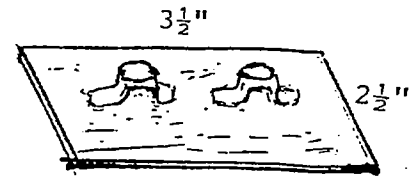

'57-'62 Brake hoses fr & rr
\$19.50 each

'55 Chrys. brake hoses fr & rr
\$19.50 each

A. 2 button rear spring interliner reproduced in very hard urethane to simulate original canvas type with metal buttons. Used on early ('50s & early '60s) cars.

B. 2 button done in very hard black urethane to duplicate orig. on later cars.

C. Single oval button interliner used on early cars reproduced in very hard black urethane.

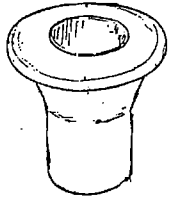

#555

'66 A-body lic. wire grommet \$3.50
Two small holes. Will need to
be split to install wires and super
glued back together.

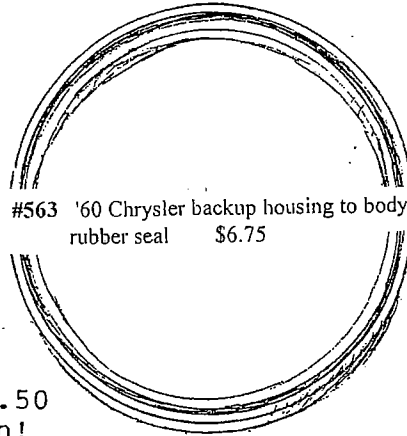

#563 '60 Chrysler backup housing to body
rubber seal \$6.75

355. Heavy duty strut rod bushing kit
(both sides included)

- A. '57-'64 Chrys., Desoto, Imp. All
'57-'64 Ply., Dodge all exc. A-Body
'65 B-Body, '60-'62 A-Body
- B. '66-'73 B-Body, '65-'73 Imp.
'70-'73 E-Body
- C. '65-'73 Fury, '65-'73 Chrysler
'65-'73 Monaco, Polara; Custom 880
- D. '63-'73 A-body

GREASE SEALS ALL \$4.50
Super bargain!

'56-'62 exc. Imp. front drum

'63-'70 all front (state make,
model, disc, and drum.)

UPPER & LOWER CONTROL ARM BUSHINGS

#523 '58-'62 low priced C-body
'63-'64 All C-body lower

#525 '62-'76 A-body, lower
'62-'71 B-body, lower
'70-'74 E-body, lower

#526 '65-'73 C-body, upper

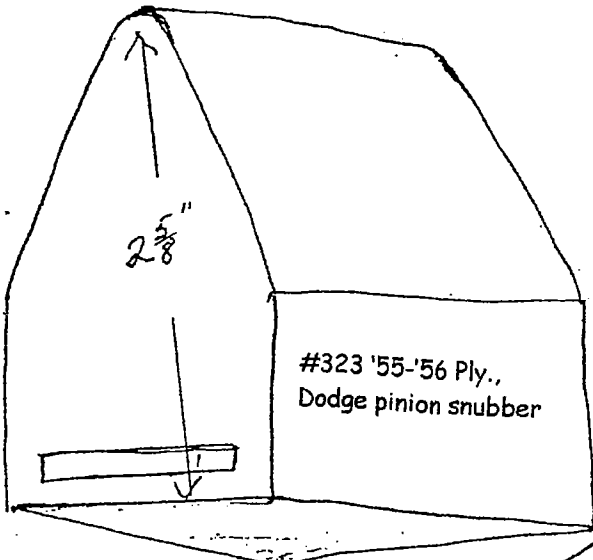

#323 '55-'56 Ply.,
Dodge pinion snubber

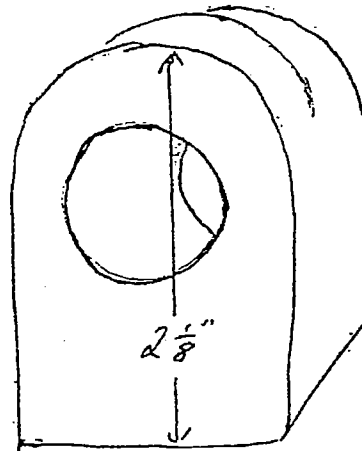

151, '71-'72 B-body
sway bar bushing

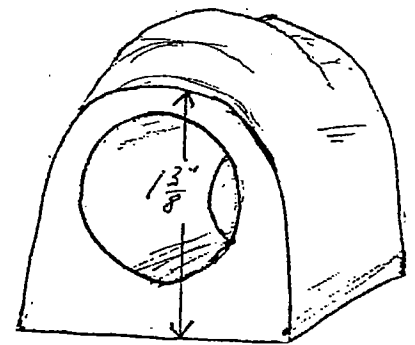

#325 '67-'68 Imp
Sway Bar bushing

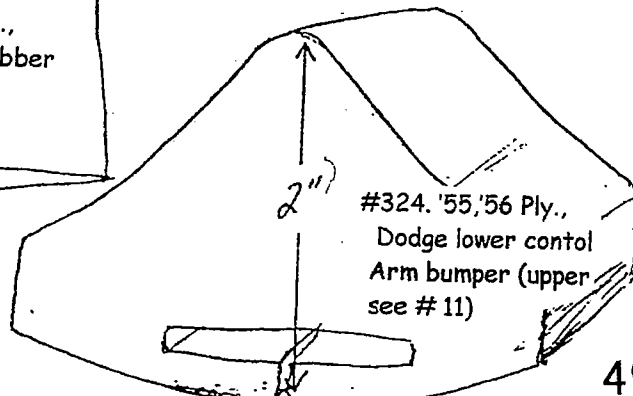

#324. '55-'56 Ply.,
Dodge lower control
Arm bumper (upper
see # 11)

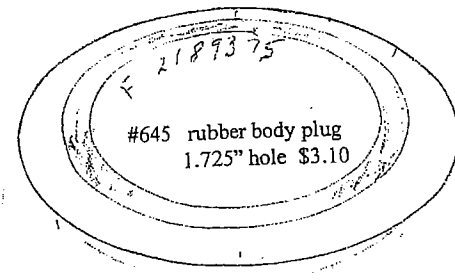

#645 rubber body plug
1.725" hole \$3.10

ONE PIECE WINDSHIELD & BACK GLASS SEALS WITH MOLDED CORNERS

sorry to bring bad news on the molded corner windshield seals. I had several made after years of frustration. The extrusions were great, quality was great except the corners could have been a little better, but all in all really good EXCEPT--apparently most of them were made with the extrusions too long. Better than too short I guess, but a problem none the less. The real bad news is that the company has basically either been giving me empty promises or completely ignoring me for better than a year. I've lost more money than I care to think about and can't continue to do so. I only have seals left for the cars listed below. With a rare possible exception, the extrusions will be too long, so I have reduced the price to \$150 each instead of \$185. I've been told by many restoration shops that the extra length isn't a big problem. They just cut off the extra near one corner and use window weld to butt the ends together when installing the glass.

- WS-1 '57-'59 All except Imperial windshields seal
 WS-2 '60-'64 All C-body except Imperial windshield seal
 BS-2 '60-'62 Chrysler, '60-'61 Desoto 2 door hard top large back glass.

Extrusions without molded corners are on page 39. These have worked for years. A pain to work with to be sure, but can be done with a little patience, a helper and window weld.

NEW CHROME IN STOCK!!!

- CHR110 '55-'56 chrys., Des., convt. 8 pc. visor bracket set.
 CHR111 '55-'56 Dodge, Ply. convt. 8 pc. visor bracket set.
 (Clearing the '55-'56 visor bracket sets out for less than the replacement cost (\$320.00) NOW \$260.00/set!
 CHR112 '57-'58 Chrys., Des. dual rear antenna base \$55.00each
 CHR113 '56 Dodge dual rear antenna base \$55.00each
 CHR114 '57 Fury script-Chrome with checkered "F" \$80.00each
 CHR115 '60-'61 swivel seat switch bezel & knob. (not done yet but will be soon) ask for price
 CHR116 '59 Dodge 500 gold & chrome emblem (will be completed soon) \$130.00 estimate
 CHR117 '60 Chrysler back-up light housing \$85.00each
 CHR118 '62 "300H" for trunk \$70.00/set
 CHR36 '58, '60-'61 wheel cover center domes \$75.00each (Beautiful repro. made with studs installed to ease assembly.)
 CHR119 '57 300 & Imperial wheel cover dome "ears". \$17.00each
 CHR78 '60-'61 swivel seat release handles \$32.00
 CHR28 '60-'61 300 side medallions bezels are now in stock \$110.00each
 CHR120 '60 300 grill bars \$300.00/set
 CHR2-7 '57-'61 side medallion numbers and letters always in stock! \$76.00per/side
 #542 '57-61 side medallions-injection molded plastic in steel dies, not poured urethane! Always in stock! \$60.00each

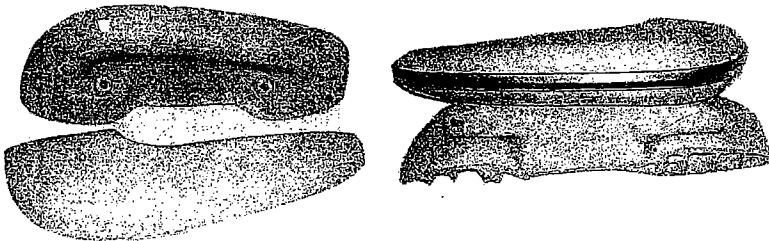

'55-'56 Chrysler 300 and New Yorker door armrest bases and pads.

Bases are molded hard urethane (consistency of plastic). They will need to be sanded, primed and painted. Arm rest pads are redone with new dense foam pad and vinyl covered as original. Send your original pads to reuse the steel cores. Colors other than black and 300 beige: You will have to send enough vinyl to use. Important Note: The bases were very hard to mold due to the limited availability of good originals. The right side original was quite nice; the best left side out of six available was warped very badly and the process of straightening it out and doing some "body work" on it resulted in shrinkage--enough that the steel base for the pad has to be shortened a bit. There was even some refitting needed on the good right side. So: If you order bases and pads I will fit them so you will have a simple screw on operation once you paint them. If you only order pads I will leave them alone assuming you have decent original bases.

'55 Note: The one piece molded '55 armrests all are turning into goo and have been for decades. Vinyl dye won't work. Remolding them as done originally isn't impossible, it's just not affordable. The '56 bases and pads look almost identical and thus are a great replacement. The stainless trim from the '55 pads will work on the '56 units. The only problem at this time is coming up with the steel cores for the pads. I'm working on this, but they're not available yet. If you can make your own, I will drill the holes for the attaching screws and fine tune them to fit. Will mail you a pattern if need be. Stainless trim is not included

708 Pads-pair \$65
 709 Molded bases \$80

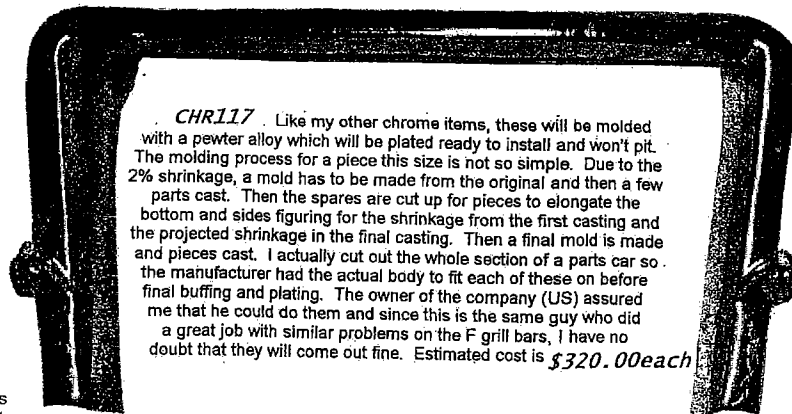

CHR117 Like my other chrome items, these will be molded with a pewter alloy which will be plated ready to install and won't pit. The molding process for a piece this size is not so simple. Due to the 2% shrinkage, a mold has to be made from the original and then a few parts cast. Then the spares are cut up for pieces to elongate the bottom and sides figuring for the shrinkage from the first casting and the projected shrinkage in the final casting. Then a final mold is made and pieces cast. I actually cut out the whole section of a parts car so the manufacturer had the actual body to fit each of these on before final buffing and plating. The owner of the company (US) assured me that he could do them and since this is the same guy who did a great job with similar problems on the F grill bars, I have no doubt that they will come out fine. Estimated cost is \$320.00each

Update--They are on the way via FedEx as of 5/5/10. I expect them any day, but have to get the catalog to the printer. The manufacturer assured me that they are beautiful. I estimated the cost at \$300, but they came in a bit higher. Still a great deal at \$320 especially compared to the one on eBay that went for over \$500!

NEW REPRODUCTION CHROME PARTS

Replace your old pitted chrome with new parts for about the same price as rechroming. The difference is these are high quality special alloy reproductions that won't pit!

Here's the complete list of parts being reproduced now. No, they are not all done yet; I expect completion soon. Those marked with an * are done and they are beautiful. Keep in mind that these are not crude sand cast brass; they are high quality molded alloy parts which are chrome or 24K gold plated and are ready to install. You'll love them or your money back.

Listed according to year

CHR17*	'55-'56 "CHRYSLER" 300 nose letters, set	\$120.00
CHR18*	'55 300 front emblem	135.00
CHR19*	'55 300 rear emblem	155.00
CHR71*	'55 C69, C70 "IMPERIAL" deck lid script	80.00
CHR68*	'55-'56 "CHRYSLER" dash panel script	34.00
CHR66*	'55 "DODGE" hood and trunk script	54.00
CHR57*	'55-'56 "DE SOTO" hood and trunk letters, set	105.00
CHR58*	'55-'56 DeSoto roof or quarter medallion base	43.00
CHR83*	'55 "CHRYSLER 300" quarter panel trim, set	160.00
CHR72*	'55-'56 "IMPERIAL" dash panel script	34.00
CHR94*	'55 "DELUXE" script [use with CHR73]	32.00
CHR73*	'56 "NEW YORKER" fender script	57.00
CHR74	'56 "IMPERIAL" rear door or quarter letters, set	
CHR84*	'56 "CHRYSLER 300B" quarter panel trim, set	165.00
CHR104*	DeSoto "SPORTSMAN", 6.25in long, gold	55.00
CHR69*	'56 Chrysler interior and front fender ornament [shield], gold/paint detail	55.00
CHR69*	'57-'58 Chrysler, non-300, dash ornament [shield], gold/paint detail	55.00
CHR64*	'56 Plymouth Forward Look quarter panel ornament, two-tone chrome May be used on other lines	60.00
CHR63	'56 "DODGE" hood script	
CHR20*	'56 300 front emblem	135.00
CHR21*	'56 300 rear emblem	155.00
CHR27*	'57-'59 300 side medallion bezel	85.00
CHR29*	'57-'58 300 trunk medallion bezel, 2pcs.	140.00
CHR30	'57-'59 300 brake air scoop bezel, L or R	
CHR31*	'57-'59 300 brake air scoop bezel extension, L or R	95.00
CHR32*	'59 300 trunk medallion bezel, 2pcs.	150.00
CHR33*	'57-'59 all makes Sta/Wgn rear seat lift handle	24.00
CHR34*	'57-'59 interior small "FIREFLITE" script	45.00
CHR35*	'57-'59 interior small "ADVENTURER" script <i>Gold</i>	75.00
CHR1*	'57-'59 300 "CHRYSLER" hood letters, set	120.00
CHR2*	'57-'61 300 "300" side medallion numbers, each side	57.00
CHR3*	'57 300 letter "C" for side medallion	19.00
CHR4*	'58 300 letter "D" for side medallion	19.00
CHR5*	'59 300 letter "E" for side medallion	19.00
CHR6*	'60 300 letter "F" for side medallion	19.00
CHR7*	'61 300 letter "G" for side medallion	19.00
CHR8*	'57-'58 glovebox door medallion base	32.00
CHR9*	'57-'59 Chrysler, DeSoto inside door handle, L or R	45.00
CHR10A*	'56-'60 "ADVENTURER" quarter panel script, gold	105.00
CHR10B*	'56-'60 "ADVENTURER" quarter panel script, chrome	80.00
CHR11*	'56-'60 "FIREFLITE" fender script	95.00
SUNVISOR MOUNTING PLATES [CHR12-CHR16]		
CHR12*	'57 all makes, exc. cvt., L or R	35.00
CHR13*	'58-'59 all makes cvt., L or R	35.00
CHR14*	'58-'59 all makes, exc. cvt., L or R	35.00
CHR15*	'60-'64 all makes, exc. cvt., L or R	35.00
CHR15*	'65-'66 A-body, exc. cvt., L or R	35.00
CHR16*	'60-'64 all makes C-body cvt., L or R	40.00
CHR22*	'57-'58 "DESOTO" hood letters, gold, set	115.00
CHR23*	'57-'58 "DESOTO" trunk letters, gold, set	105.00
CHR65*	'56-'57 DeSoto Adventurer quarter panel Forward Look, chrome/gold	95.00
CHR107*	'57 DeSoto lower rear quarter pinchweld trim--cars w/o bumper ext'ns	85.00

See page 50 for new items!

CHR24*	'57 DeSoto front fender side ornament	\$ 75.00
CHR70*	'57 "CHRYSLER" decklid name plate	85.00
CHR96*	'57-'58 "CHRYSLER" dash script	75.00
CHR69*	'56 Chrysler interior and front fender ornament [shield]	55.00
CHR69*	'57-'59 Chrysler non-300 dash ornament [shield]	55.00
CHR75*	'57-'59 "IMPERIAL" fender and trunk script	90.00
CHR76	'57-'59 Imperial trunk lid handle and decal	75.00
CHR79*	'57 "DODGE" hood letters, gold	95.00
CHR80*	'57 "DODGE" trunk letters, chrome	95.00
CHR99*	'57 Dodge "D500" ornament	130.00
CHR81*	'57-'59 Imperial crown over headlights, gold	50.00
CHR88*	'57-'59 all makes fender mount antenna base	32.00
CHR89*	'57-'59 nut used with CHR88 for power antenna	18.00
CHR90	'57-'58 Chrysler, DeSoto rear antenna base	
CHR91*	'57 "NEW YORKER" fender script	95.00
CHR86	'57-'59 all makes cvt. top latch	
CHR109*	'58 Dodge D500 emblem	135.00
CHR93*	'58 "NEW YORKER" fender script	110.00
CHR87*	'58-'64 "300" interior numbers, set	55.00
CHR36*	'58, '61-'63 300 wheel cover center dome	80.00
CHR100*	'59 300E "300" hood numbers	65.00
CHR101*	'59 300E "300" trunk numbers	70.00
CHR25*	'59 "DESOTO" hood and trunk letters	95.00
CHR26 *	'59 DeSoto Firelite quarter panel emblem bezel	60.00
CHR106*	'59 DeSoto Sta/Wgn tailgate "EXPLORER" script	70.00
CHR60*	'59 Plymouth "V" on trunk lid	35.00
CHR61	'59 Dodge trunk and fender ornament	
CHR62*	'59 Dodge trunk letters, set	82.00
CHR85*	'59 DeSoto fender top ornament	115.00
CHR77*	'59 swivel seat release handle	32.00
CHR105*	'60 DeSoto interior "ADVENTURER" script	28.00
CHR37*	'60 "CHRYSLER" hood script, gold	65.00
CHR38*	'60 Chrysler trunk lid handle	39.00
CHR78*	'60-'61 swivel seat release handle	32.00
CHR59*	'60 "CHRYSLER" script and shield under trunk	110.00
CHR97*	'60 Plymouth "SONORAMIC COMMAND POWER" emblem	110.00
CHR67*	'60-'62 "NEW YORKER" glovebox script, gold	75.00
CHR103*	'60-'61 "CHRYSLER" glovebox script, gold	75.00
CHR82*	'61 "CHRYSLER" nameplate under trunk	90.00
CHR92*	'62-'63 Imperial nose ornament, 3pcs	180.00
CHR86	'63-'66 A-body cvt, top latch	
CHR56*	'63-'72 Pentastar ornament, right lower fender	24.00
CHR39*	'63 Dart "DODGE" hood letters	62.00
CHR40*	'63 Dart hood emblem bezel	34.00
CHR41*	'63 Dart "GT" fender ornament	53.00
CHR41*	'64 Dart "GT" roof panel ornament	53.00
CHR43*	'63-'64 Dart, Valiant park light bezel	72.00
CHR44*	'63 "DART" quarter panel script	42.00
CHR45*	'65-'66 Dart fancy "GT" roof panel ornament	65.00
CHR46*	'65 Dart "DODGE" hood script	42.00
CHR47*	'65-'66 "DART" quarter panel letters	50.00
CHR49*	'65 Dart GT "DODGE" trunk letters	57.00
CHR48*	'65 Dart GT lower fender and door ornament, L or R	42.00
CHR47*	'66 "DART" fender letters	50.00
CHR49*	'66 Dart "DODGE" hood letters	57.00
CHR50*	'66 Dart exc. GT "DODGE" script on trunk lid	54.00
CHR51*	'66 Dart 270 fender side [louvers] ornament	42.00
CHR108*	'66 Dart convert end pieces for top boot snap stud trim strip	46.00
CHR52*	'68 Dodge Coronet "DODGE" letters below trunk lid	75.00
CHR53*	'68 Dodge "CORONET 440" or "CORONET 500" on quarter panel	150.00
CHR54*	'68 Dodge Coronet "500" grille ornament	65.00
CHR55*	'68 Round side marker light bezels, flat or beveled	25.00
CHR95*	'68-'70 B-body manual antenna base	18.00

#542 '57-'61 300 reproduction side medallions. Beautiful accurate duplicates of originals from a steel injection mold. All holes are drilled for letters and numbers. Chrome numbers and letters not included. New ones can be found on the reproduction chrome page 46.

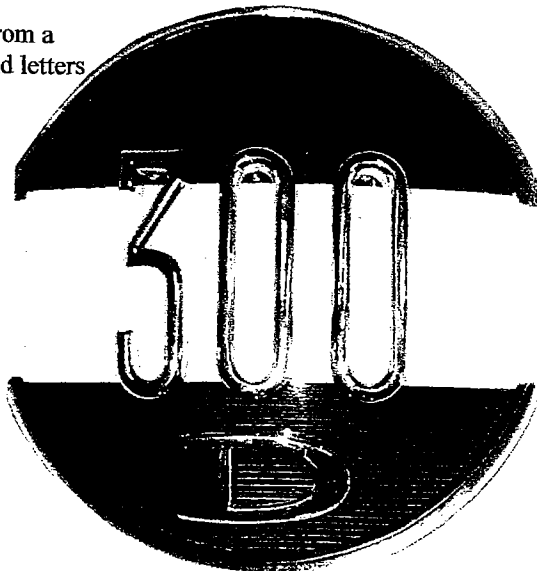

REPRODUCTION SEAT FRAME & FLOOR PLASTIC

Accurate vacuum formed black plastic. Beautiful duplicates of original hard to find parts.

RP1 '57 Electric seat side covers. 2 door. except Imp. & Ply. (black Only) \$200.00/ set.

RP2 '57-'58 Cover between electric-seat track and floor. 27" long. All except Imp. & Ply. \$105.00/set

RP3 '59 cover between electric-seat Track and floor. All except Imp. & Ply. \$105.00/set

RP4 '57-'58 Imperial cover between electric-seat track and floor \$120.00/set

RP5 '59-'61 Imperial cover between electric-seat track and floor \$100.00/set.

RP6 '58, '59-'61 without swivel. Electric seat adjuster cover. \$120.00/set

RP7 '59 swivel seat adjuster cover, with power seat. \$105.00/set

RP8 '60-'61 swivel seat adjuster cover, with power seat. \$105.00/set

RP9 '59-'61 swivel seat adjuster cover, with Manual seat. \$105.00/set

RP10 '60-'61 300 swivel seat pivot bracket covers \$105.00/set

RP11 '60-'61 All Except 300 swivel seat pivot bracket covers. \$105.00/set

RP12 '60-'61 '60-'61 All swivel seat, with wire, except 300 wire bracket covers on seat frame. \$65.00/set

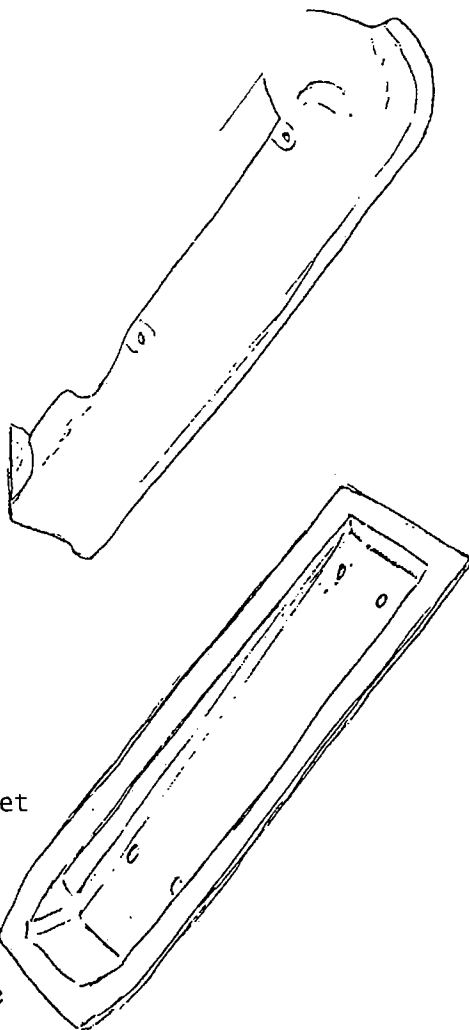

New Speedometer & Tachometer Cables !

Original type flexible steel casing
LIMITED QUANTITY NOS '62 & up A-body ... 60" long casing ... \$35.00

**Generic lengths
'61 and earlier**

'56 & earlier Chrysler ... 79" ... \$38.00 each
'57-'61 all ... 70" ... \$35.00 each

I'm very limited on samples for various years, so if you order with your original measurements of casing length, I'll make the cable to your specs.
Price will be that of the nearest generic length.

Auto Pilot Cables

'58-'61 trans to unit ... 50" \$38.00
'58-'64 unit to speedometer ... 29" \$25.00

Once again can make to your specs.
All Trans to Auto Pilot housings and cables
Are heavy duty size as original.

Tachometer Cables

'60-'62 300 tachometer cables, original extra large casing size ... \$40.00 each

NEW REPRODUCTION LENSES

These are the highest quality available !

You'll be pleased or your money back !

The normal average 15% shipping will be excessive on most of these. You can guess lower or if you add 15%, I'll refund the difference.

TAILLIGHT LENSES

#647	'55 Chrysler	\$125.00ea.
#648	'56 Chrysler	\$125.00ea.
#649	'57 Chrysler	\$240.00pr.
#650	'58 Chrysler	\$250.00pr.
#651	'59 Chrysler	\$125.00ea.
#652	'60 Chrysler	\$280.00pr.
#653	'61 Chrysler	\$250.00pr.
#654	'62 Chrysler	\$125.00ea.
#655	'57-'58 Desoto (set of 6 including back-up)	\$340.00set
#656	'59 Desoto (set of 6 including back-up)	\$340.00set
#657	'59 Imperial	\$100.00ea.
#658	'59 Dodge	\$70.00ea

PARKING LENSES

#692	'55-'56 300	\$96.00pr.
#546	'57 Chrysler '57-'59 300	\$160.00pr.
#659	'58-'59 Chrysler	\$37.00ea.
#660	'60 Chrysler	\$96.00pr.
#661	'61-'62 Chrysler	\$110.00pr.
#694	'57 Dodge	\$105.00pr.
#693	'58 Plymouth	\$105.00pr.
#662	'58 Dodge	\$35.00ea.
#663	'59 Dodge	\$80.00ea.
#664	'57 Desoto	\$80.00ea.
#665	'58 Desoto	\$35.00ea.
#666	'59 Desoto	\$40.00ea.

BACK-UP LENSES

#667	'55 Chrysler	\$45.00ea.
#668	'56 Chrysler	\$80.00ea.
#669	'57 Chrysler	\$100.00ea.
#670	'58 Chrysler	\$100.00ea.
#711	'59 Dodge	\$80.00ea.
#671	'60 Chrysler	\$40.00ea.

COURTESY LIGHT LENSES (dome)

#672	'55-'56 Chrysler HT	\$40.00ea.
#330	'57-'59 Chrysler, Desoto, Dodge, Ply. HT	\$38.00ea.
#673	'57-'59 Chrysler, Desoto, Ply., Dodge sedan & Stationwag.	\$40.00ea.
#548	'56-'64 Convertible, also console through '64	\$15.00ea
#547	'60 Chrysler HT	\$45.00ea.

LICENSE PLATE LENSES

#674	'57-'58 Dodge	\$40.00ea
#675	'57-'58 Chrysler, Desoto	\$40.00ea.

WASHER BAGS

New reproduction washer bags are in stock. As with some other items, this project has been years of frustration. The ones that are done are very nice. The ones with the nipples aren't done and likely won't be. Same for the '59 bags. The company which initially supplied great products in a very timely fashion turned sour in the middle of the projects and managed to rip me off for too much money to think about. Fortunately I did get lots of much needed bags, but the likelihood of getting more is very poor. A workable solution for the bags such as '64 A & B bodies and '61-'64 C bodies with the electric pump is to use the bags without the nipples using a cap with a hole for the hose to the washer pump.

Quantity discount! 3-5 bags--10% off, 6-10 bags--15% off, more than 10bags--20% off.



541A '55-'56 all, later trucks. \$70

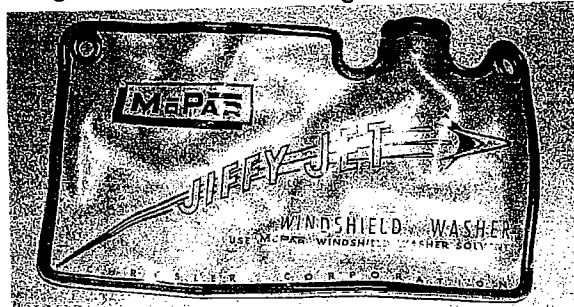

541B '57-'58 all
\$70

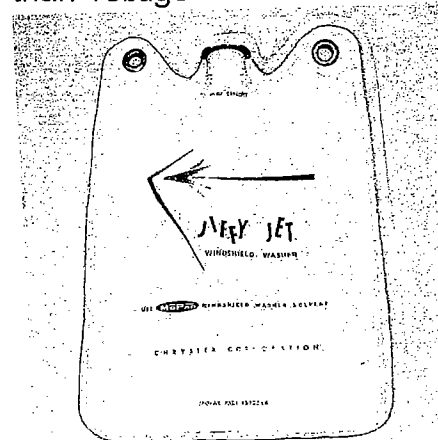

541D '60-'61 Dodge, Ply.
full size cars
Light gray
\$65



541E '62-'64 full size cars
Black
\$65

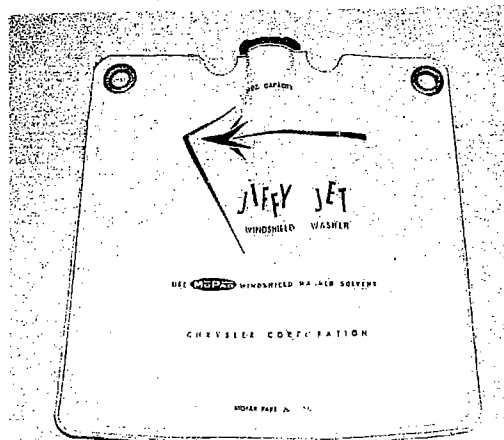

541C '60-'63 A & B bodies
Light gray
\$65

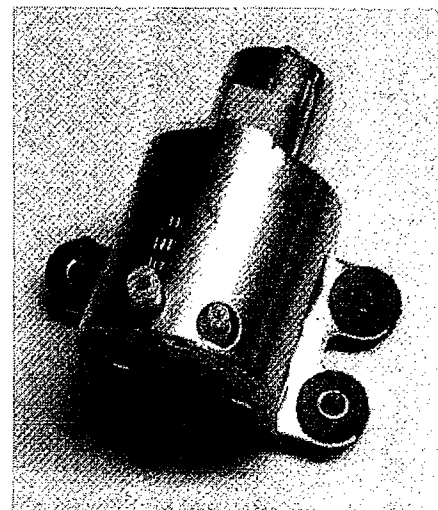

690 NOS washer pump '61-'64
\$95 (very limited quantity)

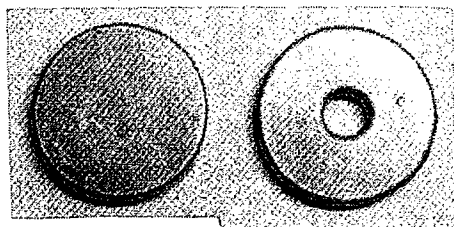

686 New washer bag caps
A. blank, no hole
B. hole for hose
C. threaded hole for valve
'55-'56, '60-'63 A & B bodies
All are \$12 each. \$8 with bag purchase

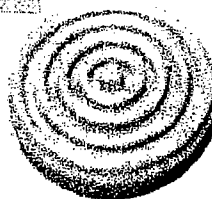

#697 '55-'56 New reproduction of hard to find gray rubber pad for washer foot pedal. Slips over aluminum base. \$8.00



687 Reproduction washer valve '55-'59 all, '60-'63 A & B bodies. These are very nice reproductions with a molded simulated metal "bottle cap" top painted green to look original; no rust, no leak!
\$25 each, \$20 each for more than one

688 Washer hose
A. Small size \$0.45/ft.
B. Large size \$0.50/ft.

A NOTE ON RUBBER PARTS

Virtually all the small rubber parts are made with room temperature curing urethane. This is the only economically feasible way to make so many different parts which are all very low demand, commercially speaking. They turn out very well and I'm always using the latest compounds available for the best quality. The weatherstrips are commercially made exclusively for me in the USA. They are made of the highest quality material available. Many have been in service for over 20 years and still good. PLEASE NOTE: I can't make parts with steel cores unless you send me your original cores with your order so I can reuse the metal. Please do not send cores that are broken or have studs broken or missing. In such cases, burn off the rubber and repair the core before sending it. The exceptions to repairing are #127 and 128. Repairs on this thin steel usually result in the core not fitting in the mold. Since it is common for these pieces to be broken with pieces missing, I've had new steel made for both #127 and #128. Cost is \$5 each. I would rather use your old ones if they are good, but at least new ones are an option.

ORDERS AND PAYMENTS

Since most items are hand produced after I receive your order you really won't save much, if any, time by FAXING in an order. However, FAXing a copy of the order you put in the mail will at least give me a heads up on parts I need to make and could save some time. If you just have to have one or two parts in an emergency (like the car is almost together and you forgot to order a key part so you can continue) FAX the order and I'll do my best to get it out quickly. On any request such as this, remember to include your shipping address and phone number even if you are a repeat customer. Saves time and sometimes even a whole day. Remember, poor planning on your end is not an emergency on my end. Trying to get me on the phone is not very productive. I am usually running around (ok hobbling around these days) like some madman trying to get items made and shipped, so the phone is generally ignored. If you have a question, FAX it or, and I hate to say it, or email it. Please, and I'm begging here, try not to email or FAX asking questions that are already answered in the catalog. I'm a one man and one girl shop. Her job is trimming parts, filling orders, cutting out upholstery material etc. She also handles emails and FAXes, but taking up a good part of her day with communications really throws a monkey wrench in the works. I don't have a hood pad for a '64 Rambler, side trim for a Chevy or even any hard parts or trim pieces for '55 and later Chrysler products. Wish I did, but any I had are long gone. On the last page I've listed the few vendors who may be able to help you or steer you in the right direction. I don't keep track of who has what as this information changes quickly. The internet is certainly a great help in finding rare parts. Good old US mail is what I'm used to handling. The order arrives with your check and cores if needed and everything goes smoothly. If you are not sure exactly which part fits your car, just describe it and I'll sort it out (I'll even call you if necessary). I often catch wrong parts ordered for a specific model and change it. With this in mind, if your order contains parts for more than one car, please tell me so I won't assume you ordered the wrong part. Just guess on the money in that case and I'll refund or bill you the difference. Your personal check is fine with me. There is no reason to go through the trouble of getting a money order or cashier's check. I do not go through the trouble of waiting for checks to clear to ship an order. Often an order will get to the customer before I even deposit the check. When the order comes, the check goes in an envelope for deposit and the order is marked paid. I make a deposit every week or two or even longer, so the check could be deposited the next day or a few weeks later; just depends on when it arrives. When your check clears has no bearing whatsoever on when your order is done and shipped. Out of country checks or money orders must be in US funds. Personal Canadian checks are ok in US funds. Overseas checks should be international money orders. A new twist now is that the banks now charge \$5 for any check or money order that does not have a US bank routing number. So, you'll have to add this to your total. I am not set up to take credit cards, but can take payment through PayPal under my email address. I only ask that you add the 4% that PayPal charges me.

RETURNS

Simple--you don't like it, return it for a refund (naturally unused). However, unless I messed up you pay all shipping. "Shotgun" orders --ordering a bunch of parts in case you need them and then returning ones you don't use-- is not appreciated. It holds up everyone including you. Order what you need.

PRICES

All items are priced as fairly as possible. Over the last few years the prices of materials and manufacturing have gone up tremendously; many have almost doubled in less than 5 years! Catalog #8 was in print for more than 5 years and prices only went up a little. #9 was around for many years and I had to constantly try to keep up with increases, but I couldn't keep up with many things resulting in reality shock when I restocked. From the look of things, I'll continue to have trouble keeping up with prices in #10, so beware, I must warn you, prices are subject to change without notice. As a painful example, most of the reproduction chrome pieces, especially ones that are slow sellers, now cost more for new batches than the prices listed in the catalog. Actually, most of the chrome items are such slow sellers (some of the original batches are almost gone, but only after 20 years) that I can't see having another batch made. When they're gone, they're gone.

TERMS

The normal business routine is you send in your order with a check for the full amount unless arrangement are made in advance. Don't fret over thinking that you added a little part later and need to pay right away or that you have old prices. It's not worth the hassle. I will send a bill in the shipment. Since there are hundreds of old catalogs out there, you can bet that the prices are old if

PRICE LIST CATALOG #9 11/09
#107

RECEIVED 1/12/11

1.	12.20	57.	1.70	102E.	3.70	117.	15.75	159A.	1.25	202.	2.70	264.	1.35
2.	8.85	58.	1.50	102F.	11.55	118.	6.60	159B.	1.25	203.	2.50	265.	2.10
3.	10.10	59.	2.85	102G.	6.60	119.	17.00	162A.	6.65	204.	2.65	266.	3.50
4.	1.25	60.	33.50	102H.	6.60	120.	9.00	162B.	6.50	205.	3.50	267.	5.40
5.	1.25	61.	2.60	102 I.	3.65	121.	4.60	163.	9.75	206A.	7.50 pr	268.	3.55
6.	1.25	62.	8.65	102 J.	8.20	122.	3.65	164.	1.50	206B.	8.50 pr	269.	5.40
7.	2.25	63.	10.25	102K.	7.45	123.	2.00	165.	2.55	207.	2.50	270.	2.35
8.	2.25	64.	2.25	102L.	4.85	124.	14.65	167A.	1.00	208.	3.45	272A.	12.00 ea
9.	1.55	65.	37.20	102M.	7.15	125.	2.95	167B.	1.15	209.	3.45	272b.	12.00 ea
10.	1.55	66.	8.50	102N.	14.90	126.	15.00 pr	167C.	1.15	210.	8.00	273.	54.00
11.	12.10	67.	9.25	102O.	9.20	127.	35.00 pr	168.	7.60	211.	2.65	274.	4.20
12.	1.25	68.	14.00	102P.	19.40	128.	35.00 pr	169.	1.10	212.	2.65	275.	2.10
13.	2.20	69.	15.00	102Q.	10.00	129.	2.45	170.	1.10	213.	3.00	276.	2.85
14.	1.95	70.	10.90	102R.	10.00	130.	2.00	171A.	.75	214.	52.00	277.	2.60
15.	2.05	71.	9.20	102S.	5.50	131.	2.50	171B.	.75	215.	13.00	278.	6.85
16.	2.35	72.	15.40 pr	102T.	9.55	132.	10.50	173.	1.35	216.	3.00	280.	2.15
17A.	8.85 pr.	73.	24.40	102U.	11.85	133.	1.75	174A.	1.05	217.	3.50	281.	2.85
17B.	9.85 pr	74.	24.40	102V.	11.85	134.	1.75	174B.	1.05	218.	3.60	282.	2.10
18.	2.05	75.	10.50	102W.	9.50	135A.	.35	175.	.85	219.	3.00	283A.	2.10
19.	2.05	76.	22.40	102X.	8.95	135B.	.35	176.	.80	220.	2.50	283B.	2.10
20.	2.25	77.	35.40	102Y.	6.30	135C.	.35	177.	22.00	221.	3.00	284.	26.70
21.	2.25	78.	1.95	102Z.	18.10	135D.	.35	178A.	.45	222.	1.95	285.	54.00
22.	1.75	79.	9.30	102AA.	7.75	135E.	.35	178B.	.45	223.	1.95	286A.	2.50
23.	2.65	80A.	7.30	102BB.	11.60	135F.	.35	178C.	.40	224.	1.95	286B.	2.50
24A.	10.65	80B.	7.30	102CC.	10.85	135G.	.35	178D.	.50	225.	1.80	287.	8.85
24B.	10.65	80C.	7.30	102DD.	7.30	135H.	.30	179.	1.05	226.	19.25	288.	2.65
25.	12.20	81.	7.30	102EE.	11.30	135 I.	.30	180A.	.85	227.	6.65	289.	2.75
26.	2.25	82.	26.70	102FF.	6.90	135 J.	.35	180B.	.80	228.	2.00 ea	290.	1.25
27.	4.60	83.	25.85	102GG.	10.50	135K.	.35	181.	7.90	229.	1.00	291.	3.95
28.	4.60	84.	26.70	102HH.	8.10	135L.	.35	185A.	.50	230.	1.00	292.	7.10
29.	4.60	85.	24.70	102 II.	11.90	135M.	.35	185B.	.45	231.	1.00	293.	13.80
30.	8.75	86.	12.30	102 JJ.	11.90	135N.	.35	185C.	.50	232.	1.60	294A.	2.50
31A.	1.25	87.	12.20	102KK.	12.50	136A.	.30	185D.	.50	233.	7.90	294B.	1.25
31B.	1.25	88.	13.20	102LL.	5.75	136B.	.30	186.	.85	234.	3.75	295.	9.50
32.	1.25	89.	5.50	102MM.	8.75	136C.	.35	187.	7.25	235.	3.85	296.	3.10
33.	1.45	90.	18.45	102NN.	3.45	136D.	.35	188.	.85	236.	3.00	297.	7.75
34A.	42.00	91.	3.85	102OO.	3.45	137.	1.50	189A.	2.50	237.	2.65	298.	24.70
34B.	39.00	92.	2.65	102PP.	10.00	138.	1.25	189B.	2.30	238.	2.75	299.	7.25
35.	7.10	93.	16.00	102QQ.	4.85	139.	1.25	189D.	3.75	239.	2.65	300.	8.10
36.	4.05	94A.	2.85	102RR.	8.10	140.	2.25	190A.	.85	240.	15.00	301.	2.50
37.	2.00	94B.	14.65	102SS.	5.85	141.	1.40	190B.	.85	241.	7.80	302.	2.50
38.	14.25 pr	95.	2.65	102TT.	5.80	142A.	1.00	190C.	.90	242.	1.75	303.	2.65
39.	25.50 pr	96.	2.80	102UU.	45.00	142B.	1.00	190D.	.90	243.	1.10	304.	2.25
40.	2.75	97.	2.80	102VV.	45.00	143.	1.50	190E.	.95	244.	4.60	305.	28.50
41.	5.50	98.	6.05	102WW.	11.30	144.	1.00	190F.	1.05	245.	1.05	306.	2.65
42.	2.50	99.	2.10	102XX.	6.75	145.	.45	190G.	1.10	246.	2.00	307.	1.70 ft
43.	2.55	100A.	2.25	102YY.	4.10	146A.	.65	190H.	1.15	247.	2.00	308.	.75
44A.	2.50	100B.	2.25	102ZZ.	9.50	146B.	.80	190 I.	1.20	248.	2.00	309A.	21.20 pr
44B.	3.00	101A.	1.40	103.	7.30	147A.	.65	190 J.	1.25	249.	62.00	309B.	28.50 pr
45.	2.50	101B.	.95	104.	2.80	147B.	.95	191.	2.50	251.	3.50	310.	3.50
46.	2.50	101C.	.95	105.	15.00	148.	.95	192A.	6.00	252.	26.70	311.	2.20
47.	2.50	101D.	1.15	106.	15.00	149.	17.00	192B.	5.50	253.	24.70	312.	14.00 pr
48.	2.50	101E.	1.30	107.	15.80	150.	1.75	193.	2.50	254.	13.00	313.	2.50
49A.	3.60	101F.	1.50	108.	16.00	151.	7.30	194A.	5.20	255.	3.10	314.	2.95
49B.	4.05	101G.	1.65	109.	7.85	152.	1.00	194B.	4.30	256.	9.35 pr	315.	2.50
50.	2.20	101H.	1.75	110.	2.50	153.	1.75	195.	5.50	257.	28.50	316A.	16.20
51.	3.75	101 I.	1.25	111.	4.60	154.	1.20	196.	5.50	258.	20.50 pr	316B.	16.20
52.	3.05	101 J.	1.45	112.	10.10 pr	156A.	3.90	197.	11.25	259.	42.00	317A.	14.00
53.	2.15	102A.	5.50	113.	6.50	156B.	3.60	198.	3.65	260.	4.40	317B.	14.00
54.	2.00	102B.	7.85	114.	2.50	157.	13.40 pr	199.	2.50	261.	3.00	318A.	13.50
55.	2.50	102C.	3.65	115.	1.85	158.	10.25 pr	200.	2.60	262.	1.90	318B.	13.50
56.	1.50	102D.	5.85	116.	15.75			201.	2.65	263.	9.25	319.	6.75

320A.	2.70	371.	2.60	430.	.20	492A.	26.75 pr	MOLDING CLIPS	
320B.	8.50	372.	2.75	431.	.25	493.	1.55	2332.	.85
320C.	6.75	373.	2.60	432.	2.65	494.	1.80	2356.	.85
320D.	5.50	374.	2.60	433.	4.60	495.	1.75	2789.	.95
321.	5.45	375.	3.50 ft.	434.	4.60	496.	1.50	8386.	.85
322.	6.50	376.	2.60	435.	18.50 pr	497.	2.85	8398.	.60
323.	13.50	377.	2.60	436.	15.75 pr	498.	2.50	8399.	.70
324.	13.00	378.	7.50	437.	15.75 pr	499.	2.70	8400.	.95
325.	7.50	379.	8.50	438.	15.75 pr	500.	2.05	A12514.	.75
326.	32.00	380.	3.60	439.	2.40	501.	5.20	A12618.	1.05
327A.	16.50	382.	.75	440A.	18.50 pr	502.	22.00	A12619.	1.20
327B.	16.50	383.	.70	440B.	17.00 pr	504A.	.45	A12744.	.85
328.	35.80	384.	1.75	441.	18.75 pr	504B.	.50	A12752.	.95
329.	1.90	386.	.75	442.	26.50 pr	504C.	.55	A12943.	1.00
330.	38.00	387.	1.25	443.	2.50	505.	.15	A13164.	2.30
331.	1.75	388.	.45	444.	10.90	506.	.95	10794.	3.00
332.	2.10	389.	5.85	445.	3.80	507.	.90		
333.	20.00	390A.	16.50	446.	13.00 pr	508.	8.40		
334.	18.00	390B.	12.50	447.	13.00 pr	510.	12.00 ea		
335A.	20.25 pr	390C.	19.75	448.	3.75	511.	16.00 pr		
335B.	20.25 pr	391.	.65	449.	29.50	512.	18.00 pr		
336.	2.75	392.	15.00 ea	450A.	36.50	513.	16.00 pr		
337.	2.25	393.	4.75	450B.	36.50	514.	24.00 pr		
338.	2.95	394A.	5.25	451.	1.40	515.	6.00 pr		
339A.	4.50	394B.	4.25	452.	6.20	516.	7.00		
339B.	4.50	395.	7.65	453.	8.80	517.	7.00		
339C.	4.50	396.	1.00	454.	12.80	518.	23.00		
340.	2.95	397.	1.50	455.	6.50	519A.	5.50		
341.	28.50 pr	398.	1.60	456.	16.00 pr	519B.	5.50		
342.	2.10	400.	1.35	457.	2.60	520.	1.75		
343.	8.75 pr	401.	1.35	458.	6.50	521.	35.00		
344.	3.00	402.	7.00	459.	4.60	522.	200.00 set		
345.	15.00 pr	403.	13.50	460.	4.00 set	523.	9.20		
346.	1.75	404A.	9.25	461.	10.50 pr	525.	7.40		
347.	1.75	404B.	9.25	462.	10.50 pr	526.	10.60		
348.	9.00	405A.	5.00	463.	4.25 pr	527A.	3.45		
349.	14.00 pr	405B.	5.75	464.	see/catalog	527B.	2.85		
350.	18.00	406.	2.65	465.	5.40	527C.	2.75		
351A.	2.85	407.	1.50	466.	10.20	528.	9.00 pr		
351B.	2.95	409.	9.45	467.	15.00	529.	2.45		
353.	3.50 ea	410.	15.75	469.	12.00	531.	100.00 set		
354.	8.45	411.	14.00	470.	2.60	533.	17.00 set		
355A.	45.00	412.	14.75 pr	471.	7.50	534.	1.70		
355B.	45.00	413.	2.60	472A.	36.50	535.	2.50		
355C.	45.00	414.	3.20	472B.	36.50	536.	45.00 pr		
355D.	45.00	415.	7.50	473.	1.85	538.	2.80		
356.	8.70	416a.	2.40	475.	2.20	539.	9.50		
357.	24.50 pr	416b.	2.30	476.	15.25	541.	70.00		
358.	18.50 pr	416c.	2.30	477.	18.75 pr	542.	60.00		
359.	10.50 pr	417.	18.50 pr	478.	3.75	543.	15.00 set		
360.	18.75 pr	418A.	40.00	479.	45.00	544.	29.00 pr		
361A.	3.25	418B.	40.00	480.	19.75	545.	2.60		
361B.	3.25	419.	15.00 pr	481.	1.65				
362.	4.50	420.	2.65	482.	1.50				
363.	4.60	421.	7.50	483.	14.75				
364.	18.45	422.	2.50	484.	13.75 set				
365.	6.40	423.	1.75	485.	10.25				
366.	2.25	424.	18.25	486.	19.30 ea				
367.	2.60	425.	2.75 yd	487.	18.80 pr				
368.	2.75	426.	9.90	488.	2.60				
369.	29.00 pr	427.	28.50	489.	24.50 pr				
370.	28.00 pr	428.	.80	491.	2.00				